

Vector Inverter Terminal Blocks Printer Cable

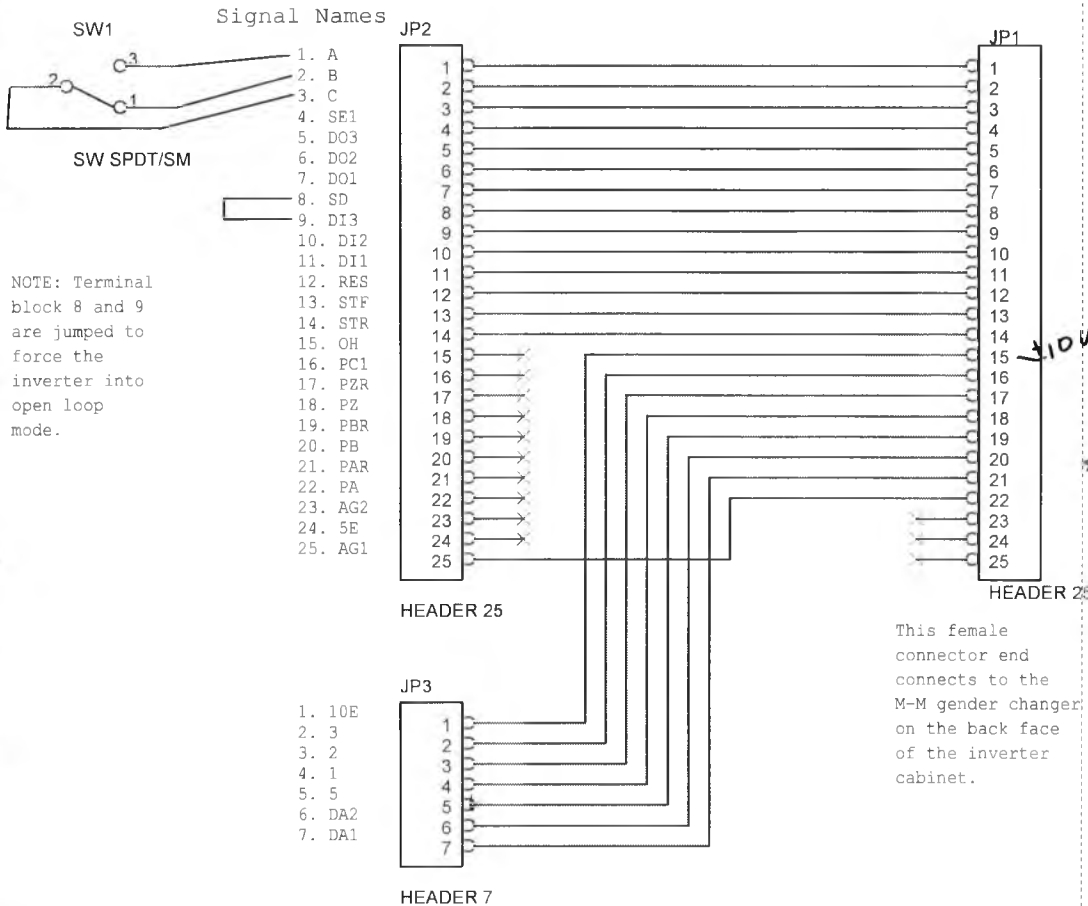

10E = 10V; 2 = signal input; 5 = Analog ground

Inside Inverter Cabinet

Printer Cable

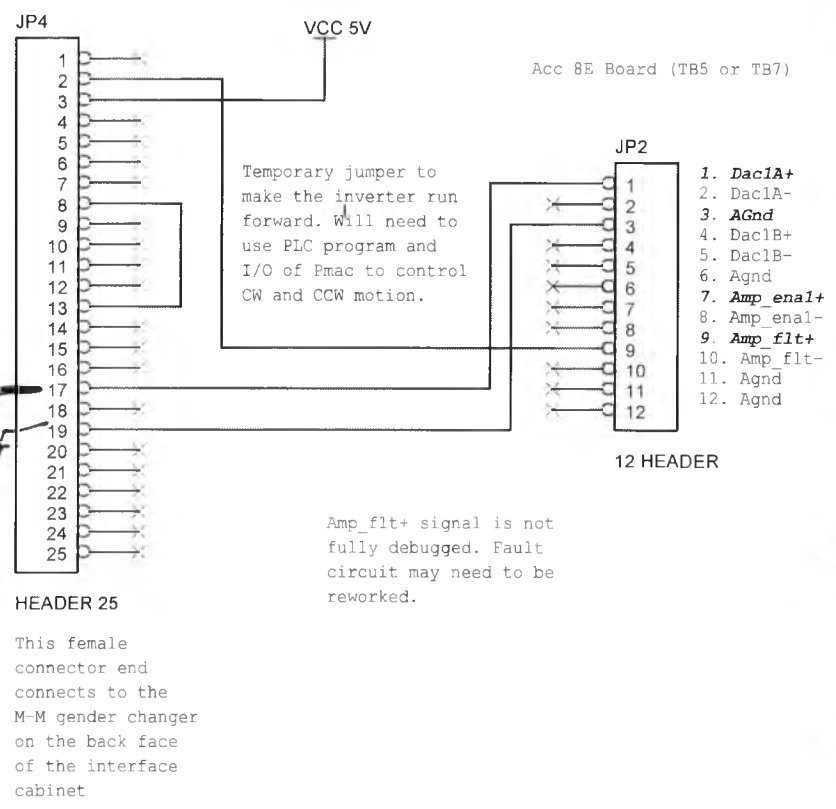

Inside Interface Cabinet

Rako Engineering		
Title Inverter Signal Wiring		
Size A	Document Number 1	Rev 2
Date:	Tuesday, September 18, 2001	Sheet 1 of 1