

HARDWARE REFERENCE MANUAL

PMAC2 PCI

PMAC 2 PCI Bus Expansion Card

4XX-603486-xHxx

May 26, 2004



DELTA TAU
Data Systems, Inc.

NEW IDEAS IN MOTION ...

Copyright Information

© 2003 Delta Tau Data Systems, Inc. All rights reserved.

This document is furnished for the customers of Delta Tau Data Systems, Inc. Other uses are unauthorized without written permission of Delta Tau Data Systems, Inc. Information contained in this manual may be updated from time-to-time due to product improvements, etc., and may not conform in every respect to former issues.

To report errors or inconsistencies, call or email:

Delta Tau Data Systems, Inc. Technical Support

Phone: (818) 717-5656

Fax: (818) 998-7807

Email: support@deltatau.com

Website: <http://www.deltatau.com>

Operating Conditions

All Delta Tau Data Systems, Inc. motion controller products, accessories, and amplifiers contain static sensitive components that can be damaged by incorrect handling. When installing or handling Delta Tau Data Systems, Inc. products, avoid contact with highly insulated materials. Only qualified personnel should be allowed to handle this equipment.

In the case of industrial applications, we expect our products to be protected from hazardous or conductive materials and/or environments that could cause harm to the controller by damaging components or causing electrical shorts. When our products are used in an industrial environment, install them into an industrial electrical cabinet or industrial PC to protect them from excessive or corrosive moisture, abnormal ambient temperatures, and conductive materials. If Delta Tau Data Systems, Inc. products are exposed to hazardous or conductive materials and/or environments, we cannot guarantee their operation.

Table of Contents

INTRODUCTION	1
Board Configuration.....	1
<i>Base Version</i>	<i>1</i>
<i>Option 1: Additional Four Channels Axis Interface Circuitry.....</i>	<i>1</i>
<i>Option 2: Dual-Ported RAM.....</i>	<i>1</i>
<i>Option 5xF: CPU Speed Options.....</i>	<i>2</i>
<i>Option 6: Extended Servo Algorithm.....</i>	<i>2</i>
<i>Option 7: Plate Mounting.....</i>	<i>2</i>
<i>Option 8: High-Accuracy Clock Crystal.....</i>	<i>2</i>
<i>Option 10: Firmware Version Specification.....</i>	<i>2</i>
<i>Option 12: Analog-to-Digital Converters.....</i>	<i>2</i>
<i>Option 16: Battery-Backed Parameter Memory.....</i>	<i>2</i>
HARDWARE SETUP	3
Piggyback CPU Board Jumper Configuration.....	3
<i>Watchdog Timer Jumper.....</i>	<i>3</i>
<i>Dual-ported RAM Source Jumper.....</i>	<i>3</i>
<i>Power-Up State Jumpers</i>	<i>3</i>
<i>Firmware Load Jumper</i>	<i>3</i>
<i>Flash Memory Bank Select Jumpers.....</i>	<i>3</i>
Base Board Jumper Configuration	3
<i>Servo and Phase Clock Direction Control.....</i>	<i>3</i>
<i>CPU Frequency Control Jumpers.....</i>	<i>4</i>
<i>Re-Initialization Jumper</i>	<i>4</i>
<i>Encoder Sample Clock Source Jumpers</i>	<i>4</i>
<i>Serial Port Selection Jumper</i>	<i>4</i>
<i>Output Disable State Jumpers</i>	<i>4</i>
Resistor Pack Configuration.....	5
<i>Termination Resistors</i>	<i>5</i>
<i>Pull-Up/Pull-Down Resistors</i>	<i>5</i>
Connections.....	6
<i>Mounting.....</i>	<i>6</i>
<i>Power Supply Connection.....</i>	<i>6</i>
<i>Machine Port Connections</i>	<i>6</i>
<i>Display Port.....</i>	<i>6</i>
<i>Multiplexer Port.....</i>	<i>7</i>
<i>I/O Port.....</i>	<i>7</i>
<i>Serial Ports</i>	<i>7</i>
<i>A/D-Converter Port</i>	<i>7</i>
<i>Handwheel Port.....</i>	<i>7</i>
COMMUNICATIONS SETUP	9
FLEX CPU BOARD JUMPER DESCRIPTIONS.....	11
E1: Watchdog Disable Jumper	11
E2: Dual-Ported RAM Port Select	11
E4 – E6: Power-Up/Reset Load Source	11
E7: Firmware Reload Enable.....	11
E10A, B, C: Flash Memory Bank Select.....	12
PMAC2 PCI BASE BOARD JUMPER DESCRIPTIONS	13
E2: CPU Frequency Select	13
E3: Normal/Re-Initializing Power-Up/Reset.....	13
E4: CPU Frequency Select	13
E5 – E6: (Reserved for Future Use)	14

E13 - E14: Encoder Sample Clock Direction Control.....14
 E17 - E18: Serial Port Type Selection.....14
 E111-118: Command Output Disable State15
MATING CONNECTORS17
 CPU Board Connectors17
 J2 (JEXP)/Expansion.....17
 Baseboard Connectors.....17
 J1 (JANA)/Analog (Option I2)17
 J2 (JTHW)/Multiplexer Port.....17
 J3 (JIO)/Digital I/O17
 J5 (JRS232)/RS-232 Serial Communications.....17
 J5A (JRS422)/RS-422 Serial Communications17
 J6 (JDISP)/Display.....17
 J7 (JHW)/Auxiliary Channel.....17
 J8 (JEQU)/Position Compare.....18
 J9 (JMACH1)/Machine Port 1.....18
 J10 (JMACH2)/Machine Port 2.....18
 J11 (JMACH3)/Machine Port 3.....18
 J12 (JMACH4)/Machine Port 4.....18
PMAC2 PCI BASE BOARD CONNECTOR PINOUTS19
 J1 (JANA) Analog Input Port Connector19
 J2 (JTHW) Multiplexer Port Connector20
 J3 (JI/O) General Input/Output Connector21
 J5 (JRS232) Serial Port Connector.....22
 J5A (RS422) Serial Port Connector22
 J6 (JDISP) Display Connector23
 J7 (JHW) Handwheel Encoder Connector.....23
 J8 (JEQU) Position Compare Output Connector.....24
 J9 (JMACH1) Connector Description24
 J9 JMACH1 Connector.....25
 J9 JMACH1 Connector.....27
 J10 (JMACH2) Connector Description27
 J11 (JMACH3) Connector Description30
 J11 JMACH3 Connector.....31
 J12 (JMACH4) Connector Description33
 J12 JMACH4 Connector.....34
 J12 JMACH4 Connector.....35
 J12 JMACH4 Connector.....36
 TB1 (2/4-Pin Terminal Block)36
 TB2 (3-Pin Terminal Block)37
BASE BOARD JUMPERS LAYOUT.....39
SCHEMATICS41

INTRODUCTION

The PMAC2 PCI (part number 400-603367-10x) is a member of the PMAC family of boards optimized for interface to sinewave or direct-PWM servo drives and to pulse-and-direction stepper drives. Its software is capable of eight axes of control. It can have up to eight channels of on-board axis interface circuitry. It can also support up to eight channels of off-board axis interface circuitry through its expansion port, connected to Acc-24P or Acc-24P2 ISA-format boards. Acc-24 boards in PCI format are not yet available.

The PMAC2 PCI is a full-sized PCI-bus expansion card, with a small piggyback board containing the CPU board. This piggyback board occupies part of the next slot, but ½-sized boards are permitted in this next slot. While the PMAC2 PCI is capable of PCI bus communications, with or without the optional on-board dual-ported RAM, it does not need to be inserted into a PCI expansion slot. Communications can be done through the standard RS-232/RS-422 serial port. Standalone operation is possible.

Board Configuration

Base Version

The base version of the PMAC2 PCI provides a 1-1/2-slot board with:

- 40MHz DSP563xx CPU (Option 5AF, 80MHz 56002 equivalent)
- 128k x 24 0-wait-state flash-backed SRAM
- 512k x 8 flash memory for user backup & firmware
- Latest released firmware version
- RS-232/RS422 serial interface, PCI bus interface
- Four channels axis interface circuitry, each including:
 - Three output command signal sets, configurable as either:
 - Two serial data streams to external DACs, 1 pulse-and-direction
 - Three PWM top-and-bottom pairs
 - 3-channel differential/single-ended encoder input
 - Nine input flags, two output flags
 - Interface to two external serial ADCs, 8 to 18 bits
- Two channels supplemental interface circuitry, each including:
 - 2-channel differential/single-ended encoder input
 - One output command signal set, configurable as pulse-&-direction or PWM top-and-bottom pair
- Display, MACRO, muxed I/O, direct I/O interface ports
- PID/notch/feedforward servo algorithms
- 1-year warranty from date of shipment
- One manual per set of one to four PMACs shipped
(Cables, mounting plates, mating connectors not included)

Option 1: Additional Four Channels Axis Interface Circuitry

- Option 1 provides an additional four channels of on-board axis interface circuitry, identical to the standard first four channels. The key components on the board are the DSPGATE1 IC at U7 and connectors J11 and J12.

Option 2: Dual-Ported RAM

Dual-ported RAM provides a very high-speed communications path for bus communications with the host computer through a bank of shared memory. DPRAM is advised if more than 100 data items per second are to be passed between the controller and the host computer in either direction.

- Option 2 provides an 8k x 16 bank of dual-ported RAM. The key component on the board is U28.

Option 5xF: CPU Speed Options

- Option 5CF: 80MHz DSP563xxx CPU (160MHz 56002 equivalent)
- Option 5EF: 160MHz DSP563xxx CPU (320MHz 56002 equivalent)
- Option 5AF: 40MHz DSP563xx CPU (80MHz 56002 equivalent) Default configuration provided automatically if no CPU option ordered.

Option 6: Extended Servo Algorithm

The standard PID servo algorithm with feedforward and notch filter is suitable for most applications. Systems with difficult dynamics, especially with significant flexibility, may require a more powerful servo algorithm, such as the Extended Servo Algorithm (ESA).

Option 7: Plate Mounting

- Option 7 provides a mounting plate connected to the PMAC2 PCI with standoffs. It is used to install the PMAC2 PCI in standalone applications.

Option 8: High-Accuracy Clock Crystal

The PMAC2 PCI has a clock crystal (component Y1) of nominal frequency 19.6608MHz (~20MHz). The standard crystal's accuracy specification is +/-100 ppm.

- Option 8A provides a nominal 19.6608MHz crystal with a +/-15 ppm accuracy specification.

Option 10: Firmware Version Specification

Normally the Turbo PMAC2 PCI is provided with the newest released firmware version. A label on the U10 flash memory IC on the CPU board shows the firmware version loaded at the factory.

- Option 10 provides for a user-specified firmware version.

Option 12: Analog-to-Digital Converters

- Option 12 permits the installation of 8 or 16 channels of on-board multiplexed analog-to-digital converters. 1 or 2 of these converters are read every phase interrupt. The analog inputs are not optically isolated, and each can have a 0 – 5V input range, or a +/-2.5V input range, individually selectable.
- Option 12 provides an 8-channel 12-bit A/D converter. The key components on the board are U28 and connector J1.
- Option 12A provides an additional 8-channel 12-bit A/D converter. The key component on the board is U29.

Option 16: Battery-Backed Parameter Memory

The contents of the standard memory are not retained through a power-down or reset unless they have been saved to flash memory first. Option 16 provides supplemental battery-backed RAM for real-time parameter storage that is ideal for holding machine state parameters in case of an unexpected power-down. The battery is located at component BT1.

- Option 16 provides a 16k x 24 bank of battery-backed parameter RAM in components U6, U9, and U15 on the CPU board.

HARDWARE SETUP

Piggyback CPU Board Jumper Configuration

Watchdog Timer Jumper

Jumper E1 on the Turbo CPU board must be OFF for the watchdog timer to operate. This is an important safety feature, so it is vital that this jumper be OFF in normal operation. E1 should be put ON only to debug problems with the watchdog timer circuit.

Dual-ported RAM Source Jumper

Jumper E2 must connect pins 1 and 2 to access dual-ported RAM from the baseboard. To use Option 2 DPRAM on the baseboard, jumper E2 must be in this setting.

Jumper E2 must connect pins 2 and 3 to access dual-ported RAM through the JEXP expansion port. To use DPRAM on an external accessory board, jumper E2 must be in this setting.

Power-Up State Jumpers

Jumper E4 on the Turbo CPU board must be OFF, jumper E5 must be ON, and jumper E6 must be ON, in order for the CPU to copy the firmware from flash memory into active RAM on power-up/reset. This is necessary for normal operation of the card. (Other settings are for factory use only.)

Firmware Load Jumper

If jumper E7 on the CPU board is ON during power-up/reset, the board comes up in bootstrap mode, which permits the loading of new firmware into the flash-memory IC on the board. When the PMAC Executive program tries to establish communications with a board in this mode, it will detect automatically that the board is in bootstrap mode and ask what file to download as the new firmware.

Jumper E7 must be OFF during power-up/reset for the board to come up in normal operational mode.

Flash Memory Bank Select Jumpers

The flash-memory IC in location U10 on the Flex CPU board has the capacity for eight separate banks of firmware, only one of which can be used at any given time. The eight combinations of settings for jumpers E10A, E10B, and E10C select which bank of the flash memory is used. In the factory production process, firmware is loaded only into Bank 0, which is selected by having all of these jumpers OFF.

Base Board Jumper Configuration

Servo and Phase Clock Direction Control

Jumper E1 should be off if the board is using its own internally generated phase and servo clock signals. In this case, these signals are output on spare pins on the J5A RS-422 serial-port connector, where they can be used by other PMAC controllers set up to take external phase and servo clock signals.

Jumper E1 should be on if the board is using externally generated phase and servo clock signals brought in on the J5A RS-422 serial port connector. In this case, another PMAC controller generates the clock signals and output is on its serial port connector. Commonly, serial communications are also shared over a multi-drop RS-422 cable, with software addressing of the cards matching the I0 serial card number for each controller. Alternately, the phase and servo clock signals can come from clock signals involved in the process.

If E1 is on for external phase and clock signals, and these clock signals are not brought in on the serial port connector, the watchdog timer will trip immediately and shut down the board.

In order to change the state of the card between use of internal clock and use of external clock, the card must be re-initialized (either powered up with jumper E3 on, or given the `$$$**` command) with jumper E1 in the new state. Before the card is reset again, a **SAVE** command must be issued to store the new internal settings.

CPU Frequency Control Jumpers

If variable I46 is set to the default value of zero, jumpers E2 and E4 on the base PMAC2 PCI board control the frequency at which the CPU will operate (or attempt to operate). Generally this will be the highest frequency at which the CPU is rated to operate.

- If jumpers E2 and E4 are both OFF, the CPU will operate at a 40MHz frequency.
- If E2 is ON and E4 is OFF, the CPU will operate at a 60MHz frequency.
- If E2 is OFF and E4 is ON, the CPU will operate at an 80MHz frequency.
- If I46 is set to a value greater than zero, E2 and E4 are not used. The CPU frequency is set to 10MHz (I46+1)

Re-Initialization Jumper

If E3 is off during power-up/reset, the controller will load its last saved set-up parameters from flash memory into active memory. This is the setting for normal operation.

If E3 is on during power-up/reset, the controller will load its factory-default set-up parameters from firmware into active memory. Generally, this is done only if communications cannot be established with the card when it comes up in normal operational mode.

Encoder Sample Clock Source Jumpers

Jumpers E13 and E14 control the source of the SCLK encoder-sampling clock for each servo IC. The default setting no jumper installed means that the SCLK signal comes from the servo IC and is output on the JMACH connectors. This setting is suitable for all but a few very special applications.

Serial Port Selection Jumper

Jumpers E17 and E18 control which serial-port connector is used. If E17 and E18 connect their pins 1 and 2, the 10-pin RS-232 port connector J5 is used. If E17 and E18 connect their pins 2 and 3, the 26-pin RS-422 port connector J5A is used. The RS-422 port must be used if several cards are to be daisy-chained together on a single multi-drop cable.

Output Disable State Jumpers

Jumpers E111 through E118 control the hardware state of the digital command output signals for each channel when the amplifier enable signal for that channel is in the disable state (false). Jumper E11 n ($n = 1$ to 8) controls the output signals for channel n on the board.

If E11 n is off (default), the command output signals for channel n are still active when the amplifier enable signal is in the disable state. The Turbo PMAC software should be commanding a net zero command to be output on these signals and the amplifier enable signal should be used by the amplifier so that no command output will cause action if it is receiving a disable signal. The off setting should be used when DAC output format is selected for the channel.

If E11 n is on, the command output signals for channel n are tri-stated when the amplifier-enable signal is in the disable state. This setting is used only with direct-PWM power-block amplifiers that do not use amplifier enable to gate the PWM signals, and in which the zero-command format of 50% top on-time, and 50% bottom on-time cannot be tolerated in the disable state.

Resistor Pack Configuration

Termination Resistors

The PMAC2 PCI provides sockets for termination resistors on differential input pairs coming into the board. As shipped, there are no resistor packs in these sockets. If these signals are brought long distances into the PMAC2 PCI board and ringing at signal transitions is a problem, SIP resistor packs may be mounted in these sockets to reduce or eliminate the ringing.

All termination resistor packs have independent resistors (no common connection) with each resistor using two adjacent pins. The following table shows which packs are used to terminate each input device:

Input	Pack	Pack Size	Input	Pack	Pack Size
Encoder 1	RP46	6-pin	ADC 1 & 2	RP60	8-pin
Encoder 2	RP50	6-pin	ADC 3 & 4	RP61	8-pin
Encoder 3	RP47	6-pin	ADC 5 & 6	RP121	8-pin
Encoder 4	RP51	6-pin	ADC 7 & 8	RP122	8-pin
Encoder 5	RP107	6-pin	Fault 1 & 2	RP63	6-pin
Encoder 6	RP111	6-pin	Fault 3 & 4	RP64	6-pin
Encoder 7	RP108	6-pin	Fault 5 & 6	RP124	6-pin
Encoder 8	RP112	6-pin	Fault 7 & 8	RP125	6-pin
SCLK12&34	RP52	6-pin	SCLK56&78	RP113	6-pin

Pull-Up/Pull-Down Resistors

The differential input signal pairs to the PMAC2 PCI have user-configurable pull-up/pull-down resistor networks to permit the acceptance of either single-ended or differential signals in one setting, or the detection of lost differential signals in another setting.

The '+' inputs of each differential pair each have a hard-wired 1 kohm pull-up resistor to +5V. This cannot be changed.

The '-' inputs of each differential pair each have a hard-wired 2.2 kohm resistor to +5V; each has another 2.2 kohm resistor as part of a socketed resistor pack that can be configured as a pull-up resistor to +5V, or a pull-down resistor to GND.

If this socketed resistor is configured as a pull-down resistor (the default configuration), the combination of pull-up and pull-down resistors on this line acts as a voltage divider, holding the line at +2.5V in the absence of an external signal. This configuration is required for single-ended inputs using the '+' lines alone; it is desirable for unconnected inputs to prevent the pick-up of spurious noise. It is permissible for differential line-driver inputs.

If this socketed resistor is configured as a pull-up resistor (by reversing the SIP pack in the socket), the two parallel 2.2 kohm resistors act as a single 1.1 kohm pull-up resistor, holding the line at +5V in the absence of an external signal. This configuration is required if encoder-loss detection is desired; or if complementary open-collector drivers are used. It is permissible for differential line-driver inputs even without encoder loss detection.

If Pin 1 of the resistor pack (marked by a dot on the pack) matches Pin 1 of the socket (marked by a wide white line on the front side of the board and a square solder pin on the back side of the board), then the pack is configured as a bank of pull-down resistors. If the pack is reversed in the socket, it is configured as a bank of pull-up resistors.

The following table lists the pull-up/pull-down resistor pack for each input device:

Device	Resistor Pack	Device	Resistor Pack
Encoder 1	RP43	ADC/Fault1&2	RP58
Encoder 2	RP48	ADC/Fault3&4	RP59
Encoder 3	RP44	ADC/Fault5&6	RP119
Encoder 4	RP49	ADC/Fault7&8	RP120
Encoder 5	RP104	SCLK12&34	RP62
Encoder 6	RP109	SCLK56&78	RP123
Encoder 7	RP105		
Encoder 8	RP110		

Connections

Mounting

The PMAC2 PCI can be mounted in one of two ways: in the PCI bus, or using standoffs.

- **PCI bus:** To mount in the PCI bus, simply insert the P1 card-edge connector into the PCI socket. If there is a standard PC-style housing, a bracket at the end of the PMAC2 PCI board can be used to screw into the housing to hold the board down firmly.
- **Standoffs:** At each of the four corners of the PMAC2 PCI board, there are mounting holes that can be used to mount the board on standoffs.

Power Supply Connection

The standard PMAC2 PCI requires only 5V power: 3A in a 4-channel configuration, 4A in an 8-channel configuration (with Option 1). If the Option 12 A/D converters are installed, a -12V supply is also required. In this case, a +12V supply also can be passed through the card and out to the analog devices feeding the A/D converters.

The power can be provided in several ways:

- **Bus connector:** If the PMAC2 PCI is mounted in an electrically active PCI bus slot, it automatically draws its 5V and +/-12V power from the bus.
- **Terminal block:** The TB1 2/4-point terminal block can be used to bring in 5V power, especially in standalone applications. Point 1 is GND; Point 2 is +5V. Points 3 and 4 are needed only if the Option-12 A/D converters are ordered.
- **JMACH connectors:** Up to 2A may be brought in through each 100-pin JMACH connector from an Acc-8 board or its equivalent, provided the cable is 500mm (20 inches) or less in length.

Machine Port Connections

The PMAC2 PCI has a 100-pin high-density header for each pair of servo interface channels. Through this connector pass all of the digital signals to and from the amplifier, encoder, and flags for the two channels. Typically, this header is connected with a matching Delta Tau Acc-8 family 2-channel breakout board or equivalent through a provided 100-pin flat cable.

The machine port connectors are:

- J9 (JMACH1) Board Channels 1 and 2
- J10 (JMACH2) Board Channels 3 and 4
- J11 (JMACH3) Board Channels 5 and 6 (Option 1 required)
- J12 (JMACH4) Board Channels 7 and 8 (Option 1 required)

Display Port

The J6 (JDISP) display port provides a 14-pin IDC header for connection to the Acc-12 family of displays. Flat cables are provided with each of these displays for direct connection between the display and this port.

Multiplexer Port

The J2 (JTHW) multiplexer port provides eight TTL-compatible 5V CMOS inputs and eight TTL-compatible 5V CMOS outputs on a 26-pin IDC header. These can be used directly as general-purpose digital I/O, or with PMAC2's special M-variable support (TWB, TWD, TWR, and TWS formats), they can be used to support hundreds, or even thousands of multiplexed I/O points on accessory boards.

Delta Tau provides the following accessory boards that can be connected to the multiplexer port. Each comes with a flat cable for direct connection to the port.

- Acc-8D Option 7 Resolver-to-Digital Converter Board
- Acc-18 Thumbwheel Board
- Acc-34 family of Digital I/O Boards
- Acc-35A and B Extender Boards

I/O Port

The J3 (JIO) I/O port provides 32 TTL-compatible 5V CMOS I/O points on a 40-pin IDC header. Direction is selectable by byte. These are used as general-purpose digital I/O points. Acc-21A provides a convenient connections adapter from this port to OPTO-22 style boards.

Serial Ports

The PMAC2 PCI has two serial-port connectors. Only one of these can be used in an application. J5 is a 10-pin IDC header for RS-232 communications. It can be connected to a standard DB9 RS-232 connector on a host computer or terminal via a flat cable such as the Acc-3L. A commercially available DB9-to-DB25 adapter can be added to this flat cable if the host computer or terminal has a DB25 serial connector. Jumpers E17 and E18 on the PMAC2 PCI must connect pins 1 and 2 to use this port.

J5A is 26-pin IDC header for RS-422 communications. It can be connected to a standard DB25 RS-422 connector on a host computer or terminal via a flat cable such as the Acc-3D. Jumpers E17 and E18 on the PMAC2 PCI must connect pins 2 and 3 to use this port.

A/D-Converter Port

If the Option 12 A/D converters are ordered, the J1 (JANA) analog-input port is provided on the PMAC2 on a 20-pin IDC header. Option 12 provides eight analog inputs at 0 – 5V, or +/-2.5V levels. Option 12A provides eight additional analog inputs at these levels. The +12V and –12V supplies can either be brought in on this connector, or brought out on it for the external analog circuitry, if they have been brought in through TB1 or P1.

Handwheel Port

The J7 (JHW) handwheel port provides two limited supplemental channels, each with a 2-channel encoder input, and a pulse-and-direction or PWM top-and-bottom pair output. All inputs and outputs are digital 5V differential line-driver pairs.

COMMUNICATIONS SETUP

Delta Tau provides communication tools that take advantage of the PCI bus Plug and Play feature of 32-bits Windows® based computers. Starting with MOTIONEXE.EXE version 10.32.00, which is included in PEWIN32 version 2.32 and newer, a PMAC2 PCI board plugged in a PCI bus slot will be recognized by the operating system when the computer is booted up. The available PCI address, dual-ported RAM address and Interrupt lines are set automatically by the operating system and can be checked (but not modified) in the MOTIONEXE.EXE application.

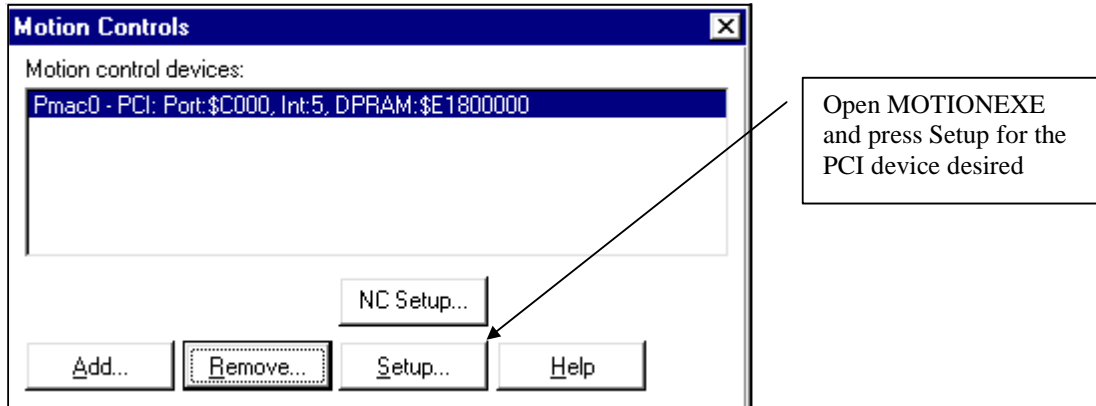

The PMAC2 PCI board may have the optional on-board dual-ported RAM circuitry, which is ordered through Option-2. If the dual-ported RAM circuitry is not on-board, manually disable its automatically assigned use through the setup page of MOTIONEXE:

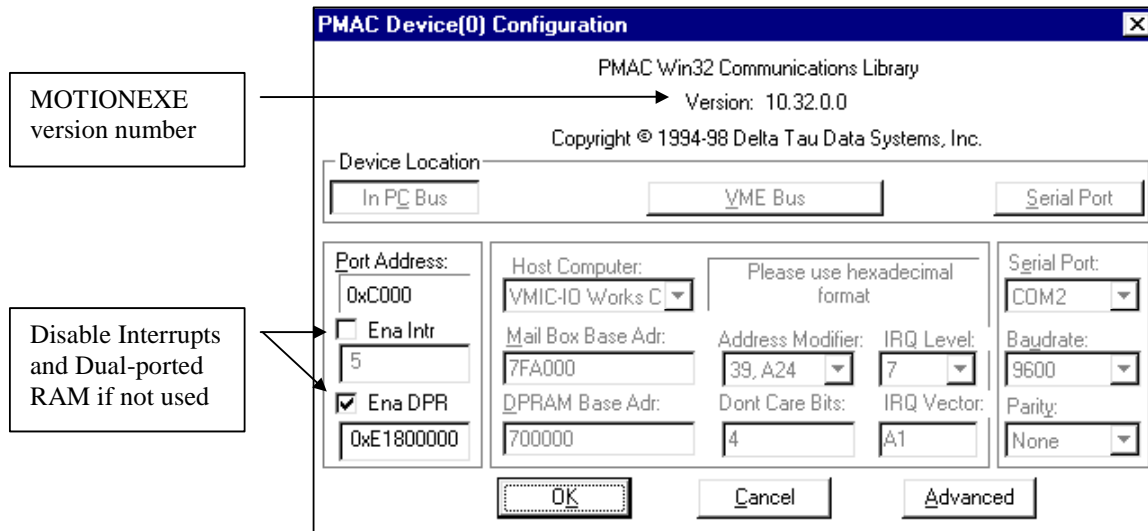

The MOTIONEXE application will look first for PMAC PCI boards on the PCI bus and will assign device numbers sequentially from Device0 to each PMAC PCI until all the PMAC PCI boards found have a device number assigned. Then, manually add other devices for either ISA bus or Serial port communications.

After each PMAC has a device number assigned to it, communications through the PCI bus are identical to the ISA bus. Any application written for the ISA bus using the Delta Tau provided 32-bits communication libraries provided will not require any further change and the process is transparent.

Note:

For example, if a Device0 for serial RS-232 communications was defined before a PMAC PCI board was installed in the computer, its setup information will be overwritten by the MOTIONEXE application when the PMAC2 PCI board is found. Therefore, it is very important to take note of the all the devices and their parameters defined in MOTIONEXE before installing a new PMAC board in the computer.

FLEX CPU BOARD JUMPER DESCRIPTIONS

E1: Watchdog Disable Jumper

E Point and Physical Layout	Description	Default
<p>E1</p> 	<p>Jump pin 1 to 2 to disable Watchdog timer (for test purposes only). Remove jumper to enable Watchdog timer.</p>	No jumper installed

E2: Dual-Ported RAM Port Select

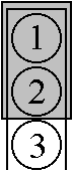
E Point and Physical Layout	Description	Default
<p>E2</p> 	<p>Jump pin 1 to 2 to access DPRAM from baseboard. Jump pin 2 to 3 to access DPRAM through JEXP expansion port.</p>	Pins 1 and 2 jumpered

E4 – E6: Power-Up/Reset Load Source

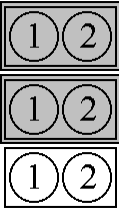
E Point and Physical Layout	Description	Default
<p>E6</p>  <p>E4</p>	<p>Remove jumper E4; Jump E5 pin 1 to 2; Jump E6 pin 2 to 3; to read flash IC on power-up/reset Other combinations are for factory use only; the board will not operate in any other configuration.</p>	<p>No E4 jumper installed; E5 and E6 jump pin 1 to 2</p>

E7: Firmware Reload Enable

E Point and Physical Layout	Description	Default
<p>E7</p> 	<p>Jump pin 1 to 2 to reload firmware through serial or bus port Remove jumper for normal operation.</p>	No jumper installed

E10A, B, C: Flash Memory Bank Select

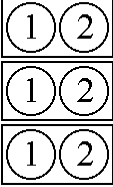
E Point and Physical Layout	Description	Default
<p>E10A</p>  <p>E10C</p>	<p>Remove all three jumpers to select flash memory bank with factory-installed firmware.</p> <p>Use other configuration to select one of the seven other flash memory banks.</p>	<p>No jumpers installed</p>

PMAC2 PCI BASE BOARD JUMPER DESCRIPTIONS

E1: Servo and Phase Clock Direction Control

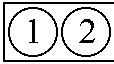
E Point and Physical Layout	Location	Description	Default
<p>E1</p> 	C2	<p>Remove jumper for PMAC2 PCI to use its internally generated servo and phase clock signals and to output these signals on the J5A serial port connector.</p> <p>Jump pins 1 and 2 for PMAC2 PCI to expect to receive its servo and phase clock signals on the J5A serial port connector.</p>	No jumper installed
<p>Note: If the E1 jumper is ON and the servo and phase clocks are not brought in on the J5A serial port, the watchdog timer will trip immediately.</p>			

E2: CPU Frequency Select

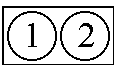
E Point and Physical layout	Location	Description	Default
<p>E2</p> 	C2	<p>Remove jumper for 40MHz operation (E4 OFF also) or for 80MHz operation (E4 ON) with I46 = 0.</p> <p>Jump pin 1 to 2 for 60MHz operation (E4 OFF) with I46 = 0.</p> <p>Not used if I46 > 0.</p>	<p>No jumper installed</p> <p>Jumper installed</p>

E3: Normal/Re-Initializing Power-Up/Reset

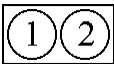

E Point and Physical Layout	Location	Description	Default
<p>E3</p> 	C2	<p>Jump pin 1 to 2 to re-initialize on power-up/reset, loading factory default settings.</p> <p>Remove jumper for normal power-up/reset, loading user-saved settings.</p>	No jumper installed

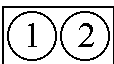
E4: CPU Frequency Select



E Point and Physical layout	Location	Description	Default
<p>E4</p> 	C2	<p>Remove jumper for 40MHz operation (E2 OFF also) or for 60MHz operation (E4 ON) with I46 = 0.</p> <p>Jump pin 1 to 2 for 80MHz operation (E2 OFF) with I46 = 0.</p> <p>Not used if I46 > 0</p>	<p>No jumper installed (standard or Option 5B)</p> <p>Jumper installed (Option 5C)</p>

E5 – E6: (Reserved for Future Use)





E13 - E14: Encoder Sample Clock Direction Control

E Point and Physical layout	Location	Description	Default
E13 	D1	<p>Remove jumper to output SCLK generated in first ASIC on SCLK_12 and SCLK_34, or to control direction by software.</p> <p>Jump pins 1 to 2 to input SCLK signal for first ASIC on SCLK_34 and output this signal on SCLK_12.</p> <p>Jump pins 2 to 3 to input SCLK signal for first ASIC on SCLK_12 and output this signal on SCLK_34.</p>	No jumper installed
E14 	D2	<p>Remove jumper to output SCLK generated in second ASIC on SCLK_56 and SCLK_78, or to control direction by software.</p> <p>Jump pins 1 to 2 to input SCLK signal for second ASIC on SCLK_78 and output this signal on SCLK_56.</p> <p>Jump pins 2 to 3 to input SCLK signal for second ASIC on SCLK_56 and output this signal on SCLK_78.</p>	No jumper installed
Note: E14 is only installed if Option 1 has been ordered.			

E17 - E18: Serial Port Type Selection

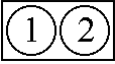
E Point and Physical layout	Location	Description	Default
E17 	C1	<p>Connect pins 1 and 2 to use the RS-232 port on the J5 connector.</p> <p>Connect pins 2 and 3 to use the RS-422 port on the J5A connector.</p>	Jumper installed in 1-2 position
E18 	C1	<p>Connect pins 1 and 2 to use the RS-232 port on the J5 connector.</p> <p>Connect pins 2 and 3 to use the RS-422 port on the J5A connector.</p>	Jumper installed in 1-2 position
Serial Port Choice: Because both RS-232 and RS-422 ports are always provided, jumpers must be set correctly to use the port of choice. Jumpers E17 and E18 must connect pins 1 and 2 to use the RS-232 port on the J5 connector; to use the RS-422 port on the J5A connector, they must connect pins 2 and 3.			

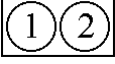
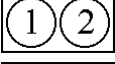
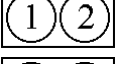
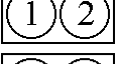
E111-118: Command Output Disable State

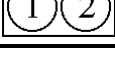
E Point and Physical Layout	Location	Description	Default
E111 	C1	Jump pin 1 to 2 of E11 n for digital servo command output signals of Channel n to tri-state when amplifier-enable signal for Channel n is in disable state.	No jumper installed
E112 			
E113 		Remove jumper for digital servo command output signals of Channel n to remain active (but typically with zero command value) when amplifier-enable signal for Channel n is in disable state.	
E114 			
E115 			
E116 			
E117 			
E118 			

MATING CONNECTORS

CPU Board Connectors

J2 (JEXP)/Expansion

- Two 50-pin female flat cable connector Delta Tau P/N 014-R00F50-0K0 - T&B Ansley P/N 609-5041
- 171-50 T&B Ansley standard flat cable stranded 50-wire
- Phoenix varioface module type FLKM 50 (male pins) P/N 22 81 08 9

Baseboard Connectors

J1 (JANA)/Analog (Option 12)

- Two 14-pin female flat cable connector Delta Tau P/N 014-R00F14-0K0 - T&B Ansley P/N 609-1441
- 171-14 T&B Ansley standard flat cable stranded 14-wire
- Phoenix varioface modules type FLKM14 (male pins) P/N 22 81 02 1

J2 (JTHW)/Multiplexer Port

- Two 26-pin female flat cable connector Delta Tau P/N 014-R00F26-0K0 - T&B Ansley P/N 609-2641
- 171-26 T&B Ansley standard flat cable stranded 26-wire
- Phoenix varioface module type FLKM 26 (male pins) P/N 22 81 05 0

J3 (JIO)/Digital I/O

- Two 40-pin female flat cable connector Delta Tau P/N 014-R00F40-0K0 - T&B Ansley P/N 609-4041
- 171-40 T&B Ansley standard flat cable stranded 40-wire
- Phoenix varioface module type FLKM 40 (male pins)

J5 (JRS232)/RS-232 Serial Communications

- Two 10-pin female flat cable connector Delta Tau P/N 014-ROOF10-0K0 - T&B Ansley P/N 609-1041
- 171-10 T&B Ansley standard flat cable stranded 10-wire
- Phoenix varioface module type FLKM 10 (male pins) P/N 22 81 01 8

J5A (JRS422)/RS-422 Serial Communications

- Two 26-pin female flat cable connector Delta Tau P/N 014-R00F26-0K0 - T&B Ansley P/N 609-2641
- 171-26 T&B Ansley standard flat cable stranded 26-wire
- Phoenix varioface module type FLKM 26 (male pins) P/N 22 81 05 0

J6 (JDISP)/Display

- Two 14-pin female flat cable connector Delta Tau P/N 014-R00F14-0K0 - T&B Ansley P/N 609-1441
- 171-14 T&B Ansley standard flat cable stranded 14-wire
- Phoenix varioface modules type FLKM14 (male pins) P/N 22 81 02 1

J7 (JHW)/Auxiliary Channel

- Two 20-pin female flat cable connector Delta Tau P/N 014-R00F20-0K0 - T&B Ansley P/N 609-2041
- 171-20 T&B Ansley standard flat cable stranded 20-wire
- Phoenix varioface modules type FLKM20 (male pins)

J8 (JEUQ)/Position Compare

- Two 10-pin female flat cable connector Delta Tau P/N 014-ROOF10-0K0 - T&B Ansley P/N 609-1041
- 171-10 T&B Ansley standard flat cable stranded 10-wire
- Phoenix varioface module type FLKM 10 (male pins) P/N 22 81 01 8

J9 (JMACH1)/Machine Port 1

- Two 100-pin high-density box header with center key, 0.050" pitch - AMP P/N 1-04068-7, Delta Tau P/N 014-00010-FPB
- High-density flat cable stranded 100-wire

J10 (JMACH2)/Machine Port 2

- Two 100-pin high-density box header with center key, 0.050" pitch - AMP P/N 1-04068-7, Delta Tau P/N 014-00010-FPB
- High-density flat cable stranded 100-wire

J11 (JMACH3)/Machine Port 3

- Two 100-pin high-density box header with center key, 0.050" pitch - AMP P/N 1-04068-7, Delta Tau P/N 014-00010-FPB
- High-density flat cable stranded 100-wire

J12 (JMACH4)/Machine Port 4

- Two 100-pin high-density box header with center key, 0.050" pitch - AMP P/N 1-04068-7, Delta Tau P/N 014-00010-FPB
- High-density flat cable stranded 100-wire

PMAC2 PCI BASE BOARD CONNECTOR PINOUTS

J1 (JANA) Analog Input Port Connector

This connector is present only if Option 12 is ordered.

Pin #	Symbol	Function	Description	Notes
1	ANAI00	Input	Analog input 0	0-5V or +/-2.5V range
2	ANAI01	Input	Analog input 1	0-5V or +/-2.5V range
3	ANAI02	Input	Analog input 2	0-5V or +/-2.5V range
4	ANAI03	Input	Analog input 3	0-5V or +/-2.5V range
5	ANAI04	Input	Analog input 4	0-5V or +/-2.5V range
6	ANAI05	Input	Analog input 5	0-5V or +/-2.5V range
7	ANAI06	Input	Analog input 6	0-5V or +/-2.5V range
8	ANAI07	Input	Analog input 7	0-5V or +/-2.5V range
9	ANAI08	Input	Analog input 8	0-5V or +/-2.5V range *
10	ANAI09	Input	Analog input 9	0-5V or +/-2.5V range *
11	ANAI10	Input	Analog input 10	0-5V or +/-2.5V range *
12	ANAI11	Input	Analog input 11	0-5V or +/-2.5V range *
13	ANAI12	Input	Analog input 12	0-5V or +/-2.5V range *
14	ANAI13	Input	Analog input 13	0-5V or +/-2.5V range *
15	ANAI14	Input	Analog input 14	0-5V or +/-2.5V range *
16	ANAI15	Input	Analog input 15	0-5V or +/-2.5V range *
17	GND	Common	PMAC common	Not isolated from digital
18	+12V	Output	Positive supply voltage	To power external circuitry
19	GND	Common	PMAC common	Not isolated from digital
20	-12V	Output	Negative supply voltage	To power external circuitry

*This signal is present only if Option-12A is ordered.
The JANA connector provides the inputs for the 8 or 16 optional analog inputs on the PMAC2.

J2 (JTHW) Multiplexer Port Connector

Pin #	Symbol	Function	Description	Notes
1	GND	Common	PMAC common	
2	GND	Common	PMAC common	
3	DAT0	Input	Data-0 input	Data input from MUX port accessories
4	SEL0	Output	Select-0 output	Address/data output for MUX port accessories
5	DAT1	Input	Data-1 input	Data input from MUX port accessories
6	SEL1	Output	Select-1 output	Address/data output for MUX port accessories
7	DAT2	Input	Data-2 input	Data input from MUX port accessories
8	SEL2	Output	Select-2 output	Address/data output for MUX port accessories
9	DAT3	Input	Data-3 input	Data input from MUX port accessories
10	SEL3	Output	Select-3 output	Address/data output for MUX port accessories
11	DAT4	Input	Data-4 input	Data input from MUX port accessories
12	SEL4	Output	Select-4 output	Address/data output for MUX port accessories
13	DAT5	Input	Data-5 input	Data input from MUX port accessories
14	SEL5	Output	Select-5 output	Address/data output for MUX port accessories
15	DAT6	Input	Data-6 input	Data input from MUX port accessories
16	SEL6	Output	Select-6 output	Address/data output for MUX port accessories
17	DAT7	Input	Data-7 input	Data input from MUX port accessories
18	SEL7	Output	Select-7 output	Address/data output for MUX port accessories
19	N.C.	N.C.	No connection	
20	GND	Common	PMAC common	
21	BRLD/	Output	Buffer request	Low is buffer required
22	GND	Common	PMAC common	
23	IPLD/	Output	In position	Low is in position
24	GND	Common	PMAC common	
25	+5V	Output	+5Vdc supply	Power supply out
26	INIT/	Input	PMAC reset	Low is reset

J3 (JI/O) General Input/Output Connector

Pin #	Symbol	Function	Description	Notes
1	I/O00	In/Out	Digital I/O 0	Software direction ctrl.
2	I/O01	In/Out	Digital I/O 1	Software direction ctrl.
3	I/O02	In/Out	Digital I/O 2	Software direction ctrl.
4	I/O03	In/Out	Digital I/O 3	Software direction ctrl.
5	I/O04	In/Out	Digital I/O 4	Software direction ctrl.
6	I/O05	In/Out	Digital I/O 5	Software direction ctrl.
7	I/O06	In/Out	Digital I/O 6	Software direction ctrl.
8	I/O07	In/Out	Digital I/O 7	Software direction ctrl.
9	I/O08	In/Out	Digital I/O 8	Software direction ctrl.
10	I/O09	In/Out	Digital I/O 9	Software direction ctrl.
11	I/O10	In/Out	Digital I/O 10	Software direction ctrl.
12	I/O11	In/Out	Digital I/O 11	Software direction ctrl.
13	I/O12	In/Out	Digital I/O 12	Software direction ctrl.
14	I/O13	In/Out	Digital I/O 13	Software direction ctrl.
15	I/O14	In/Out	Digital I/O 14	Software direction ctrl.
16	I/O15	In/Out	Digital I/O 15	Software direction ctrl.
17	I/O16	In/Out	Digital I/O 16	Software direction ctrl.
18	I/O17	In/Out	Digital I/O 17	Software direction ctrl.
19	I/O18	In/Out	Digital I/O 18	Software direction ctrl.
20	I/O19	In/Out	Digital I/O 19	Software direction ctrl.
21	I/O20	In/Out	Digital I/O 20	Software direction ctrl.
22	I/O21	In/Out	Digital I/O 21	Software direction ctrl.
23	I/O22	In/Out	Digital I/O 22	Software direction ctrl.
24	I/O23	In/Out	Digital I/O 23	Software direction ctrl.
25	I/O24	In/Out	Digital I/O 24	Software direction ctrl.
26	I/O25	In/Out	Digital I/O 25	Software direction ctrl.
27	I/O26	In/Out	Digital I/O 26	Software direction ctrl.
28	I/O27	In/Out	Digital I/O 27	Software direction ctrl.
29	I/O28	In/Out	Digital I/O 28	Software direction ctrl.
30	I/O29	In/Out	Digital I/O 29	Software direction ctrl.
31	I/O30	In/Out	Digital I/O 30	Software direction ctrl.
32	I/O31	In/Out	Digital I/O 31	Software direction ctrl.
33	GND	Common	Reference voltage	
34	GND	Common	Reference voltage	
35	PHASE/	Output	Phase clock	For latching data
36	SERVO/	Output	Servo clock	For latching data
37	GND	Common	Reference voltage	
38	GND	Common	Reference voltage	
39	+5V	Output	Supply voltage	To power external circuitry
40	+5V	Output	Supply voltage	To power external circuitry

The JI/O connector provides 32 input/output pins at TTL levels. Direction can be controlled in byte-wide groups.

J5 (JRS232) Serial Port Connector

Pin #	Symbol	Function	Description	Notes
1	PHASE	Output	Phasing clock	
2	DTR	Bidirect	Data terminal ready	Tied to DSR
DSR	TXD/	Input	Receive data	Host transmit data
4	CTS	Input	Clear to send	Host ready bit
5	RXD/	Output	Send data	Host receives data
6	RTS	Output	Req. to send	PMAC ready bit
7	DSR	Bidirect	Data set ready	Tied to DTR
8	SERVO	Output	Servo clock	
9	GND	Common	PMAC common	
10	+5V	Output	+5Vdc supply	Power supply out

The JRS232 connector provides the PMAC2-PC with the ability to communicate serially with an RS232 port. This connector cannot be used for daisy-chain interconnection of multiple PMACs. The J5A RS-422 port must be used for daisy chaining.

E17 and E18 must connect pins 1 and 2 to use the RS-232 port for serial communications.

J5A (RS422) Serial Port Connector

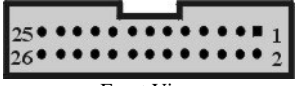
JRS422 (26-PIN Connector)				 Front View
Pin #	Symbol	Function	Description	Notes
1	CHASSI	Common	PMAC common	
2	S+5V	Output	+5Vdc supply	
3	RD-	Input	Receive data	Diff. I/O low true
4	RD+	Input	Receive data	Diff. I/O high true
5	SD-	Output	Send data	Diff. I/O low true
6	SD+	Output	Send data	Diff. I/O high true
7	CS+	Input	Clear to send	Diff I/O high true
8	CS-	Input	Clear to send	Diff. I/O low true
9	RS+	Output	Req. to send	Diff. I/O high true
10	RS-	Output	Req. to send	Diff I/O low true
11	DTR	Bidirect	Data term read	Tied to DSR
12	INIT/	Input	PMAC reset	Low is reset
13	GND	Common	PMAC common	
14	DSR	Bidirect	Data set ready	Tied to DTR
15	SDIO-	Bidirect	Special data	Diff. I/O low true
16	SDIO+	Bidirect	Special data	Diff. I/O high true
17	SCIO-	Bidirect	Special ctrl.	Diff I/O low true
18	SCIO+	Bidirect	Special ctrl.	Diff. I/O high true
19	SCK-	Bidirect	Special clock	Diff. I/O low true
20	SCK+	Bidirect	Special clock	Diff. I/O high true
21	SERVO-	Bidirect	Servo clock	Diff. I/O low true
22	SERVO+	Bidirect	Servo clock	Diff. I/O high true
23	PHASE-	Bidirect	Phase clock	Diff. I/O low true
24	PHASE+	Bidirect	Phase clock	Diff. I/O high true
25	GND	Common	PMAC common	
26	+5V	Output	+5Vdc supply	Power supply out

E17 and E18 must connect pins 2 and 3 to use the RS-422 port for serial communications. This connector could be also used to daisy chain interconnect multiple PMACs for synchronized operation.

J6 (JDISP) Display Connector

Pin #	Symbol	Function	Description	Notes
1	VDD	Output	+5V power	Power supply out
2	VSS	Common	PMAC common	
3	RS	Output	Read strobe	TTL signal out
4	VEE	Output	Contrast adjust VEE	0 to +5Vdc *
5	E	Output	Display enable	High is enable
6	R/W	Output	Read or write	TTL signal out
7	DB1	Output	Display data1	
8	DB0	Output	Display data0	
9	DB3	Output	Display data3	
10	DB2	Output	Display data2	
11	DB5	Output	Display data5	
12	DB4	Output	Display data4	
13	DB7	Output	Display data7	
14	DB6	Output	Display data6	

The JDISP connector is used to drive the 2-line x 24-character (Acc-12), 2 x 40 (Acc-12A) LCD, or the 2 x 40 vacuum fluorescent (ACC 12C) display unit. The **DISPLAY** command may be used to send messages and values to the display.

J7 (JHW) Handwheel Encoder Connector

Pin #	Symbol	Function	Description	Notes
1	GND	Common	Reference voltage	
2	+5V	Output	Supply voltage	To power external circuitry
3	HWA1+	Input	HW positive A channel	Also pulse input
4	HWA1-	Input	HW negative A channel	Also pulse input
5	HWB1+	Input	HW positive B channel	Also direction input
6	HWB1-	Input	HW negative B channel	Also direction input
7	HWA2+	Input	HW positive A channel	Also pulse input
8	HWA2-	Input	HW negative A channel	Also pulse input
9	HWB2+	Input	HW positive B channel	Also direction input
10	HWB2-	Input	HW negative B channel	Also direction input
11	PUL1+	Output	PFM positive pulse	Also PWM bottom output
12	PUL1-	Output	PFM negative pulse	Also PWM bottom output
13	DIR1+	Output	PFM positive dir out	Also PWM top output
14	DIR1-	Output	PFM negative dir out	Also PWM top output
15	PUL2+	Output	PFM positive pulse	Also PWM bottom output
16	PUL2-	Output	PFM negative pulse	Also PWM bottom output
17	DIR2+	Output	PFM positive dir. out	Also PWM top output
18	DIR2-	Output	PFM negative dir out	Also PWM top output
19	GND	Common	Reference voltage	
20	+5V	Output	Supply voltage	To power external circuitry

The VHW connector provides for two 2-channel encoder inputs and two sets of pulse outputs.

J8 (JEQU) Position Compare Output Connector

Pin #	Symbol	Function	Description	Notes
1	EQU1/	Output	Encoder 1 comp-Eq	Programmed polarity
2	EQU2/	Output	Encoder 2 comp-Eq	Programmed polarity
3	EQU3/	Output	Encoder 3 comp-Eq	Programmed polarity
4	EQU4/	Output	Encoder 4 comp-Eq	Programmed polarity
5	EQU5/	Output	Encoder 5 comp-Eq	Programmed polarity
6	EQU6/	Output	Encoder 6 comp-Eq	Programmed polarity
7	EQU7/	Output	Encoder 7 comp-Eq	Programmed polarity
8	EQU8/	Output	Encoder 8 comp-Eq	Programmed polarity
9	+V	Supply	Positive supply	+5V
10	GND	Common	Digital ground	

This connector provides the position-compare outputs for the eight encoder channels.

J9 (JMACH1) Connector Description

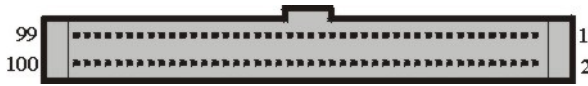
J9 JMACH1 Connector			 Front View	
Pin#	Symbol	Function	Description	Notes
1	+5V	Output / Input	+5V power	For external circuit or from external supply
2	+5V	Output / Input	+5V power	For external circuit or from external supply
3	GND	Common	Reference voltage	
4	GND	Common	Reference voltage	
5	CHA1+	Input	Encoder 1 positive A channel	Also pulse input
6	CHA1-	Input	Encoder 1 negative A channel	Also pulse input
7	CHB1+	Input	Encoder 1 positive B channel	Also direction input
8	CHB1-	Input	Encoder 1 negative B channel	Also direction input
9	CHC1+	Input	Encoder 1 positive C channel	Index channel
10	CHC1-	Input	Encoder 1 negative C channel	Index channel
11	CHU1	Input	Channel 1 U flag	Hall effect, fault code, or sub-count
12	CHV1	Input	Channel 1 V flag	Hall effect, fault code, or sub-count
13	CHW1	Input	Channel 1 W flag	Hall effect, fault code, or sub-count
14	CHT1	Input	Channel 1 T flag	Fault code, or sub-count
15	USER1	Input	General purpose user flag	Hardware capture flag, or sub-count
16	PLIM1	Input	Positive overtravel limit	Hardware capture flag
17	MLIM1	Input	Negative overtravel limit	Hardware capture flag
18	HOME1	Input	Home switch input	Hardware capture flag
19	ACCFLT1	Input	Accessory fault flag	For loss of acc supply voltage
20	WD0/	Output	Watchdog output	Low is PMAC watchdog fault
21	SCLK12+	Input / Output	Encoder sample clock	Direction controlled by PMAC2 jumper
22	SCLK12-	Input / Output	Encoder sample clock	Direction controlled by PMAC2 jumper
23	ADC_CLK1+	Output	A/D converter clock	Programmable frequency
24	ADC_CLK1-	Output	A/D converter clock	Programmable frequency
25	ADC_STB1+	Output	A/D converter strobe	Programmable sequence
26	ADC_STB1-	Output	A/D converter strobe	Programmable sequence

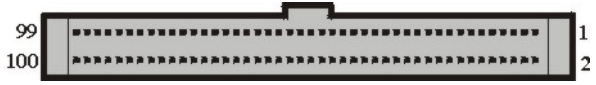
J9 JMACH1 Connector (Continued)		 <p style="text-align: center;">Front View</p>		
Pin#	Symbol	Function	Description	Notes
27	ADC_DAA1+	Input	Chan A ADC serial data	MSB first
28	ADC_DAA1-	Input	Chan A ADC serial data	MSB first
29	ADC_DAB1+	Input	Chan B ADC serial data	MSB first
30	ADC_DAB1-	Input	Chan B ADC serial data	MSB first
31	AENA1+	Output	Amplifier enable	High is enable
32	AENA1-	Output	Amplifier enable	Low is enable
33	FAULT1+	Input	Amplifier fault	Programmable polarity
34	FAULT1-	Input	Amplifier fault	Programmable polarity
35	PWMATOP1+ DAC_CLK1+	Output	Phase A top Cmd. or DAC clock	Programmable function control
36	PWMATOP1- DAC_CLK1-	Output	Phase A top Cmd. or DAC clock	Programmable function control
37	PWMBOT1+ DAC1A+	Output	Phase A bottom Cmd. or DAC A serial data	Programmable function control
38	PWMBOT1- DAC1A-	Output	Phase A bottom Cmd. or DAC A serial data	Programmable function control
39	PWMBTOP1+ DAC_STB1+	Output	Phase B top Cmd. or DAC strobe	Programmable function control
40	PWMBTOP1- DAC_STB1-	Output	Phase B top Cmd. or DAC strobe	Programmable function control
41	PWMBBOT1+ DAC1B+	Output	Phase B bottom Cmd. or DAC B serial data	Programmable function control
42	PWMBBOT1- DAC1B-	Output	Phase B bottom Cmd. or DAC B serial data	Programmable function control
43	PWMCTOP1+ DIR1+	Output	Phase B top Cmd. or PFM direction	Programmable function control
44	PWMCTOP1- DIR1-	Output	Phase B top Cmd. or PFM direction	Programmable function control
45	PWMCBOT1+ PULSE1+	Output	Phase B bottom Cmd. or PFM pulse	Programmable function control
46	PWMCBOT1- PULSE1-	Output	Phase B tottom Cmd. or PFM pulse	Programmable function control
47	GND	Common	Reference voltage	
48	GND	Common	Reference voltage	
49	+5V	Output / Input	+5V power	For external circuit or from external supply
50	+5V	Output / Input	+5V power	For external circuit or from external supply
51	+5V	Output / Input	+5V power	For external circuit or from external supply
52	+5V	Output / Input	+5V power	For external circuit or from external supply
53	GND	Common	Reference voltage	
54	GND	Common	Reference voltage	
55	CHA2+	Input	Encoder 2 positive A channel	Also pulse input
56	CHA2-	Input	Encoder 2 negative A channel	Also pulse input
57	CHB2+	Input	Encoder 2 positive B channel	Also direction input

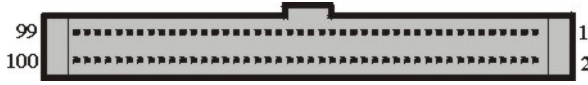
J9 JMACH1 Connector (Continued)			 <p>Front View</p>	
Pin#	Symbol	Function	Description	Notes
58	CHB2-	Input	Encoder 2 negative B channel	Also direction input
59	CHC2+	Input	Encoder 2 positive C channel	Index channel
60	CHC2-	Input	Encoder 2 negative C channel	Index channel
61	CHU2	Input	Channel 2 U flag	Hall effect, fault code, or sub-count
62	CHV2	Input	Channel 2 V flag	Hall effect, fault code, or sub-count
63	CHW2	Input	Channel 2 W flag	Hall effect, fault code, or sub-count
64	CHT2	Input	Channel 2 T flag	Fault code, or sub-count
65	USER2	Input	General purpose user flag	Hardware capture flag, or sub-count
66	PLIM2	Input	Positive overtravel limit	Hardware capture flag
67	MLIM2	Input	Negative overtravel limit	Hardware capture flag
68	HOME2	Input	Home switch input	Hardware capture flag
69	ACCFLT2	Input	Accessory fault flag	For loss of ACC supply voltage
70	WD0/	Output	Watchdog output	Low is PMAC watchdog fault
71	SCLK12+	Input / Output	Encoder sample clock	Direction controlled by PMAC2 jumper
72	SCLK12-	Input / Output	Encoder sample clock	Direction controlled by PMAC2 jumper
73	ADC_CLK2+	Output	A/D converter clock	Programmable frequency
74	ADC_CLK2-	Output	A/D converter clock	Programmable frequency
75	ADC_STB2+	Output	A/D converter strobe	Programmable sequence
76	ADC_STB2-	Output	A/D converter strobe	Programmable sequence
77	ADC_DAA2+	Input	Channel A ADC serial data	MSB first
78	ADC_DAA2-	Input	Channel A ADC serial data	MSB first
79	ADC_DAB2+	Input	Channel B ADC serial data	MSB first
80	ADC_DAB2-	Input	Channel B ADC serial data	MSB first
81	AENA2+	Output	Amplifier enable	High is enable
82	AENA2-	Output	Amplifier enable	Low is enable
83	FAULT2+	Input	Amplifier fault	Programmable polarity
84	FAULT2-	Input	Amplifier fault	Programmable polarity
85	PWMATOP2+ DAC_CLK2+	Output	Phase A top Cmd. or DAC clock	Programmable function control
86	PWMATOP2- DAC_CLK2-	Output	Phase A top Cmd. or DAC clock	Programmable function control
87	PWMAOT2+ DAC2A+	Output	Phase A bottom Cmd. or DAC A serial data	Programmable function control
88	PWMAOT2- DAC2A-	Output	Phase A bottom Cmd. or DAC A serial data	Programmable function control
89	PWMBOT2+ DAC_STB2+	Output	Phase B top Cmd. or DAC strobe	Programmable function control
90	PWMBOT2- DAC_STB2-	Output	Phase B top Cmd. or DAC strobe	Programmable function control
91	PWMBOT2+ DAC2B+	Output	Phase B bottom Cmd. or DAC B serial data	Programmable function control
92	PWMBOT2- DAC2B-	Output	Phase B bottom Cmd. or DAC B serial data	Programmable function control
93	PWMTOP2+ DIR2+	Output	Phase B top Cmd. or PFM direction	Programmable function control

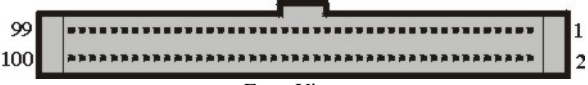
J9 JMACH1 Connector (Continued)		 Front View		
Pin#	Symbol	Function	Description	Notes
94	PWMCTOP2- DIR2-	Output	Phase B top Cmd. or PFM direction	Programmable function control
95	PWMCBOT2+ PULSE2+	Output	Phase B bottom Cmd. or PFM pulse	Programmable function control
96	PWMCBOT2- PULSE2-	Output	Phase B bottom Cmd. or PFM pulse	Programmable function control
97	GND	Common	Reference voltage	
98	GND	Common	Reference voltage	
99	+5V	Output / Input	+5V power	For external circuit or from external supply
100	+5V	Output / Input	+5V power	For external circuit or from external supply

The JMACH1 connector provides the interface pins for channels 1 and 2. Usually, it is connected to a breakout board, such as one of the Acc-8x family of boards, or an application-specific interface board.

J10 (JMACH2) Connector Description

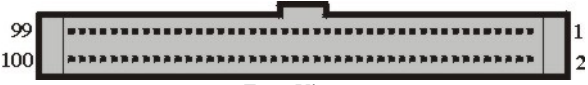
J10 JMACH2 Connector		 Front View		
Pin#	Symbol	Function	Description	Notes
1	+5V	Output / Input	+5V power	For external circuit or from external supply
2	+5V	Output / Input	+5V power	For external circuit or from external supply
3	GND	Common	Reference voltage	
4	GND	Common	Reference voltage	
5	CHA3+	Input	Encoder 3 positive A channel	Also pulse input
6	CHA3-	Input	Encoder 3 negative A channel	Also pulse input
7	CHB3+	Input	Encoder 3 positive B channel	Also direction input
8	CHB3-	Input	Encoder 3 negative B channel	Also direction input
9	CHC3+	Input	Encoder 3 positive C channel	Index channel
10	CHC3-	Input	Encoder 3 negative C channel	Index channel
11	CHU3	Input	Channel 3 U flag	Hall effect, fault code, or sub-count
12	CHV3	Input	Channel 3 V flag	Hall effect, fault code, or sub-count
13	CHW3	Input	Channel 3 W flag	Hall effect, fault code, or sub-count
14	CHT3	Input	Channel 3 T flag	Fault code, or sub-count
15	USER3	Input	General purpose user flag	Hardware capture flag, or sub-count
16	PLIM3	Input	Positive overtravel limit	Hardware capture flag
17	MLIM3	Input	Negative overtravel limit	Hardware capture flag
18	HOME3	Input	Home switch input	Hardware capture flag
19	ACCFLT3	Input	Accessory fault flag	For loss of acc supply voltage
20	WD0/	Output	Watchdog output	Low is PMAC watchdog fault
21	SCLK34+	Input / Output	Encoder sample clock	Direction controlled by PMAC2 jumper
22	SCLK34-	Input / Output	Encoder sample clock	Direction controlled by PMAC2 jumper
23	ADC_CLK3+	Output	A/D converter clock	Programmable frequency

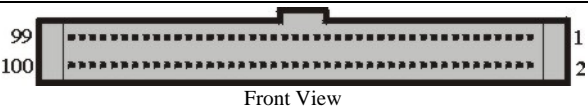
J10 JMACH2 Connector (Continued)		 <p style="text-align: center;">Front View</p>		
Pin#	Symbol	Function	Description	Notes
24	ADC_CLK3-	Output	A/D converter clock	Programmable frequency
25	ADC_STB3+	Output	A/D converter strobe	Programmable sequence
26	ADC_STB3-	Output	A/D converter strobe	Programmable sequence
27	ADC_DAA3+	Input	Channel A ADC serial data	MSB first
28	ADC_DAA3-	Input	Channel A ADC serial data	MSB first
29	ADC_DAB3+	Input	Channel B ADC serial data	MSB first
30	ADC_DAB3-	Input	Channel B ADC serial data	MSB first
31	AENA3+	Output	Amplifier enable	High is enable
32	AENA3-	Output	Amplifier enable	Low is enable
33	FAULT3+	Input	Amplifier fault	Programmable polarity
34	FAULT3-	Input	Amplifier fault	Programmable polarity
35	PWMATOP3+ DAC_CLK3+	Output	Phase A top Cmd. or DAC clock	Programmable function control
36	PWMATOP3- DAC_CLK3-	Output	Phase A top Cmd. or DAC clock	Programmable function control
37	PWMAOT3+ DAC3A+	Output	Phase A bottom Cmd. or DAC A serial data	Programmable function control
38	PWMAOT3- DAC3A-	Output	Phase A bottom Cmd. or DAC A serial data	Programmable function control
39	PWMBTOP3+ DAC_STB3+	Output	Phase B top Cmd. or DAC strobe	Programmable function control
40	PWMBTOP3- DAC_STB3-	Output	Phase B top Cmd. or DAC strobe	Programmable function control
41	PWMBBOT3+ DAC3B+	Output	Phase B bottom Cmd. or DAC B serial data	Programmable function control
42	PWMBBOT3- DAC3B-	Output	Phase B bottom Cmd. or DAC B serial data	Programmable function control
43	PWMCOT3+ DIR3+	Output	Phase B top Cmd. or PFM direction	Programmable function control
44	PWMCOT3- DIR3-	Output	Phase B top Cmd. or PFM direction	Programmable function control
45	PWMCBOT3+ PULSE3+	Output	Phase B bottom Cmd. or PFM pulse	Programmable function control
46	PWMCBOT3- PULSE3-	Output	Phase B bottom Cmd. or PFM pulse	Programmable function control
47	GND	Common	Reference voltage	
48	GND	Common	Reference voltage	
49	+5V	Output / Input	+5V power	For external circuit or from external supply
50	+5V	Output / Input	+5V power	For external circuit or from external supply
51	+5V	Output / Input	+5V power	For external circuit or from external supply
52	+5V	Output / Input	+5V power	For external circuit or from external supply
53	GND	Common	Reference voltage	
54	GND	Common	Reference voltage	
55	CHA4+	Input	Encoder 4 positive A channel	Also pulse input

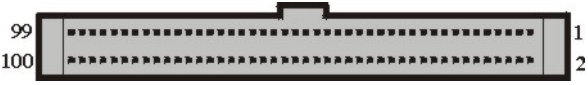
J10 JMACH2 Connector (Continued)			 <p>Front View</p>	
Pin#	Symbol	Function	Description	Notes
56	CHA4-	Input	Encoder 4 negative A channel	Also pulse input
57	CHB4+	Input	Encoder 4 positive B channel	Also direction input
58	CHB4-	Input	Encoder 4 negative B channel	Also direction input
59	CHC4+	Input	Encoder 4 positive C channel	Index channel
60	CHC4-	Input	Encoder 4 negative C channel	Index channel
61	CHU4	Input	Channel 4 U flag	Hall effect, fault code, or sub-count
62	CHV4	Input	Channel 4 V flag	Hall effect, fault code, or sub-count
63	CHW4	Input	Channel 4 W flag	Hall effect, fault code, or sub-count
64	CHT4	Input	Channel 4 T flag	Fault code, or sub-count
65	USER4	Input	General purpose user flag	Hardware capture flag, or sub-count
66	PLIM4	Input	Positive overtravel limit	Hardware capture flag
67	MLIM4	Input	Negative overtravel limit	Hardware capture flag
68	HOME4	Input	Home switch input	Hardware capture flag
69	ACCFLT4	Input	Accessory fault flag	For loss of ACC supply voltage
70	WD0/	Output	Watchdog output	Low is PMAC watchdog fault
71	SCLK34+	Input / Output	Encoder sample clock	Direction controlled by PMAC2 jumper
72	SCLK34-	Input / Output	Encoder sample clock	Direction controlled by PMAC2 jumper
73	ADC_CLK4+	Output	A/D converter clock	Programmable frequency
74	ADC_CLK4-	Output	A/D converter clock	Programmable frequency
75	ADC_STB4+	Output	A/D converter strobe	Programmable sequence
76	ADC_STB4-	Output	A/D converter strobe	Programmable sequence
77	ADC_DAA4+	Input	Channel A ADC serial data	MSB first
78	ADC_DAA4-	Input	Channel A ADC serial data	MSB first
79	ADC_DAB4+	Input	Channel B ADC serial data	MSB first
80	ADC_DAB4-	Input	Channel B ADC serial data	MSB first
81	AENA4+	Output	Amplifier enable	High is enable
82	AENA4-	Output	Amplifier enable	Low is enable
83	FAULT4+	Input	Amplifier fault	Programmable polarity
84	FAULT4-	Input	Amplifier fault	Programmable polarity
85	PWMATOP4+ DAC_CLK4+	Output	Phase A top Cmd. or DAC clock	Programmable function control
86	PWMATOP4- DAC_CLK4-	Output	Phase A top Cmd. or DAC clock	Programmable function control
87	PWMAOT4+ DAC4A+	Output	Phase A bottom Cmd. or DAC A serial data	Programmable function control
88	PWMAOT4- DAC4A-	Output	Phase A bottom Cmd. or DAC A serial data	Programmable function control
89	PWMBTOP4+ DAC_STB4+	Output	Phase B top Cmd. or DAC strobe	Programmable function control
90	PWMBTOP4- DAC_STB4-	Output	Phase B top Cmd. or DAC strobe	Programmable function control
91	PWMBBOT4+ DAC4B+	Output	Phase B bottom Cmd. or DAC B serial data	Programmable function control
92	PWMBBOT4- DAC4B-	Output	Phase B bottom Cmd. or DAC B serial data	Programmable function control

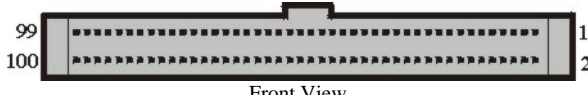
J10 JMACH2 Connector (Continued)		 <p style="text-align: center;">Front View</p>		
Pin#	Symbol	Function	Description	Notes
93	PWMCTOP4+ DIR4+	Output	Phase B top Cmd. or PFM direction	Programmable function control
94	PWMCTOP4- DIR4-	Output	Phase B top Cmd. or PFM direction	Programmable function control
95	PWMCBOT4+ PULSE4+	Output	Phase B bottom Cmd. or PFM pulse	Programmable function control
96	PWMCBOT4- PULSE4-	Output	Phase B bottom Cmd. or PFM pulse	Programmable function control
97	GND	Common	Reference voltage	
98	GND	Common	Reference voltage	
99	+5V	Output / Input	+5V power	For external circuit or from external supply
100	+5V	Output / Input	+5V power	For external circuit or from external supply

The JMACH2 connector provides the interface pins for channels 3 and 4. Usually, it is connected to a breakout board, such as one of the Acc-8x family of boards, or an application-specific interface board.

J11 (JMACH3) Connector Description

This connector is present only if Option 1 is ordered.

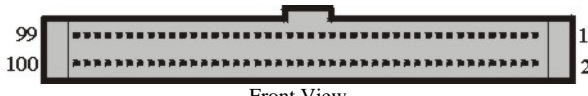
J11 JMACH3 Connector		 <p style="text-align: center;">Front View</p>		
Pin#	Symbol	Function	Description	Notes
1	+5V	Output / Input	+5V power	For external circuit or from external supply
2	+5V	Output / Input	+5V power	For external circuit or from external supply
3	GND	Common	Reference voltage	
4	GND	Common	Reference voltage	
5	CHA5+	Input	Encoder 5 positive A channel	Also pulse input
6	CHA5-	Input	Encoder 5 negative A channel	Also pulse input
7	CHB5+	Input	Encoder 5 positive B channel	Also direction input
8	CHB5-	Input	Encoder 5 negative B channel	Also direction input
9	CHC5+	Input	Encoder 5 positive C channel	Index channel
10	CHC5-	Input	Encoder 5 negative C channel	Index channel
11	CHU5	Input	Channel 5 U flag	Hall effect, fault code, or sub-count
12	CHV5	Input	Channel 5 V flag	Hall effect, fault code, or sub-count
13	CHW5	Input	Channel 5 W flag	Hall effect, fault code, or sub-count
14	CHT5	Input	Channel 5 T flag	Fault code, or sub-count
15	USER5	Input	General purpose user flag	Hardware capture flag, or sub-count
16	PLIM5	Input	Positive overtravel limit	Hardware capture flag
17	MLIM5	Input	Negative overtravel limit	Hardware capture flag
18	HOME5	Input	Home switch input	Hardware capture flag
19	ACCFLT5	Input	Accessory fault flag	For loss of ACC supply voltage
20	WD0/	Output	Watchdog output	Low is PMAC watchdog fault
21	SCLK56+	Input / Output	Encoder sample clock	Direction controlled by PMAC2 jumper

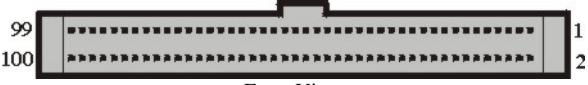
J11 JMACH3 Connector (Continued)		 <p style="text-align: center;">Front View</p>		
Pin#	Symbol	Function	Description	Notes
22	SCLK56-	Input / Output	Encoder sample clock	Direction controlled by PMAC2 jumper
23	ADC_CLK5+	Output	A/D converter clock	Programmable frequency
24	ADC_CLK5-	Output	A/D converter clock	Programmable frequency
25	ADC_STB5+	Output	A/D converter strobe	Programmable sequence
26	ADC_STB5-	Output	A/D converter strobe	Programmable sequence
27	ADC_DAA5+	Input	Channel A ADC serial data	MSB first
28	ADC_DAA5-	Input	Channel A ADC serial data	MSB first
29	ADC_DAB5+	Input	Channel B ADC serial data	MSB first
30	ADC_DAB5-	Input	Channel B ADC serial data	MSB first
31	AENA5+	Output	Amplifier enable	High is enable
32	AENA5-	Output	Amplifier enable	Low is enable
33	FAULT5+	Input	Amplifier fault	Programmable polarity
34	FAULT5-	Input	Amplifier fault	Programmable polarity
35	PWMATOP5+ DAC_CLK5+	Output	Phase A top Cmd. or DAC clock	Programmable function control
36	PWMATOP5- DAC_CLK5-	Output	Phase A top Cmd. or DAC clock	Programmable function control
37	PWMAOT5+ DAC5A+	Output	Phase A bottom Cmd. or DAC A serial data	Programmable function control
38	PWMAOT5- DAC5A-	Output	Phase A bottom Cmd. or DAC A serial data	Programmable function control
39	PWMBTOP5+ DAC_STB5+	Output	Phase B top Cmd. or DAC strobe	Programmable function control
40	PWMBTOP5- DAC_STB5-	Output	Phase B top Cmd. or DAC strobe	Programmable function control
41	PWMBBOT5+ DAC5B+	Output	Phase B bottom Cmd. or DAC B serial data	Programmable function control
42	PWMBBOT5- DAC5B-	Output	Phase B bottom Cmd. or DAC B serial data	Programmable function control
43	PWMCTOP5+ DIR5+	Output	Phase B top Cmd. or PFM direction	Programmable function control
44	PWMCTOP5- DIR5-	Output	Phase B top Cmd. or PFM direction	Programmable function control
45	PWMCBOT5+ PULSE5+	Output	Phase B bottom Cmd. or PFM pulse	Programmable function control
46	PWMCBOT5- PULSE5-	Output	Phase B bottom Cmd. or PFM pulse	Programmable function control
47	GND	Common	Reference voltage	
48	GND	Common	Reference voltage	
49	+5V	Output / Input	+5V power	For external circuit or from external supply
50	+5V	Output / Input	+5V power	For external circuit or from external supply
51	+5V	Output / Input	+5V power	For external circuit or from external supply
52	+5V	Output / Input	+5V power	For external circuit or from external supply

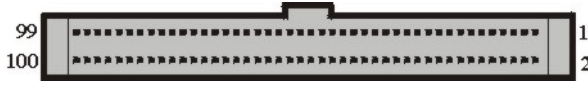
J11 JMACH3 Connector (Continued)		 <p style="text-align: center;">Front View</p>		
Pin#	Symbol	Function	Description	Notes
53	GND	Common	Reference voltage	
54	GND	Common	Reference voltage	
55	CHA6+	Input	Encoder 6 positive A channel	Also pulse input
56	CHA6-	Input	Encoder 6 negative A channel	Also pulse input
57	CHB6+	Input	Encoder 6 positive B channel	Also direction input
58	CHB6-	Input	Encoder 6 negative B channel	Also direction input
59	CHC6+	Input	Encoder 6 positive C channel	Index channel
60	CHC6-	Input	Encoder 6 negative C channel	Index channel
61	CHU6	Input	Channel 6 U flag	Hall effect, fault code, or sub-count
62	CHV6	Input	Channel 6 V flag	Hall effect, fault code, or sub-count
63	CHW6	Input	Channel 6 W flag	Hall effect, fault code, or sub-count
64	CHT6	Input	Channel 6 T flag	Fault code, or sub-count
65	USER6	Input	General purpose user flag	Hardware capture flag, or sub-count
66	PLIM6	Input	Positive overtravel limit	Hardware capture flag
67	MLIM6	Input	Negative overtravel limit	Hardware capture flag
68	HOME6	Input	Home switch input	Hardware capture flag
69	ACCFLT6	Input	Accessory fault flag	For loss of ACC supply voltage
70	WD0/	Output	Watchdog output	Low is PMAC watchdog fault
71	SCLK56+	Input / Output	Encoder sample clock	Direction controlled by PMAC2 jumper
72	SCLK56-	Input / Output	Encoder sample clock	Direction controlled by PMAC2 jumper
73	ADC_CLK6+	Output	A/D converter clock	Programmable frequency
74	ADC_CLK6-	Output	A/D converter clock	Programmable frequency
75	ADC_STB6+	Output	A/D converter strobe	Programmable sequence
76	ADC_STB6-	Output	A/D converter strobe	Programmable sequence
77	ADC_DAA6+	Input	Channel A ADC serial data	MSB first
78	ADC_DAA6-	Input	Channel A ADC serial data	MSB first
79	ADC_DAB6+	Input	Channel B ADC serial data	MSB first
80	ADC_DAB6-	Input	Channel B ADC serial data	MSB first
81	AENA6+	Output	Amplifier enable	High is enable
82	AENA6-	Output	Amplifier enable	Low is enable
83	FAULT6+	Input	Amplifier fault	Programmable polarity
84	FAULT6-	Input	Amplifier fault	Programmable polarity
85	PWMATOP6+ DAC_CLK6+	Output	Phase A top Cmd. or DAC Clock	Programmable function control
86	PWMATOP6- DAC_CLK6-	Output	Phase A top Cmd. or DAC Clock	Programmable function control
87	PWMAOT6+ DAC6A+	Output	Phase A bottom Cmd. or DAC A serial data	Programmable function control
88	PWMAOT6- DAC6A-	Output	Phase A bottom Cmd. or DAC A serial data	Programmable function control
89	PWMBTOP6+ DAC_STB6+	Output	Phase B top Cmd. or DAC strobe	Programmable function control
90	PWMBTOP6- DAC_STB6-	Output	Phase B top Cmd. or DAC strobe	Programmable function control
91	PWMBBOT6+ DAC6B+	Output	Phase B bottom Cmd. or DAC B serial data	Programmable function control

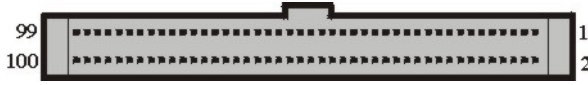
J11 JMACH3 Connector (Continued)		 Front View		
Pin#	Symbol	Function	Description	Notes
92	PWMBBOT6-DAC6B-	Output	Phase B bottom Cmd. or DAC B serial data	Programmable function control
93	PWMCTOP6+DIR6+	Output	Phase B top Cmd. or PFM direction	Programmable function control
94	PWMCTOP6-DIR6-	Output	Phase B top Cmd. or PFM direction	Programmable function control
95	PWMCBOT6+PULSE6+	Output	Phase B bottom Cmd. or PFM pulse	Programmable function control
96	PWMCBOT6-PULSE6-	Output	Phase B bottom Cmd. or PFM pulse	Programmable function control
97	GND	Common	Reference voltage	
98	GND	Common	Reference voltage	
99	+5V	Output / Input	+5V power	For external circuit or from external supply
100	+5V	Output / Input	+5V power	For external circuit or from external supply

The JMACH3 connector provides the interface pins for channels 5 and 6. It is usually connected to a breakout board, such as one of the Acc-8x family of boards, or an application-specific interface board.

J12 (JMACH4) Connector Description

This connector is present only if Option 1 is ordered.

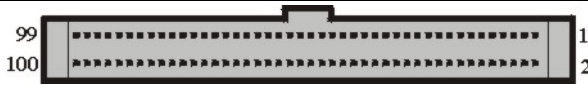
J12 JMACH4 Connector		 Front View		
Pin#	Symbol	Function	Description	Notes
1	+5V	Output / Input	+5V power	For external circuit or from external supply
2	+5V	Output / Input	+5V power	For external circuit or from external supply
3	GND	Common	Reference voltage	
4	GND	Common	Reference voltage	
5	CHA7+	Input	Encoder 7 positive A channel	Also pulse input
6	CHA7-	Input	Encoder 7 negative A channel	Also pulse input
7	CHB7+	Input	Encoder 7 positive B channel	Also direction input
8	CHB7-	Input	Encoder 7 negative B channel	Also direction input
9	CHC7+	Input	Encoder 7 positive C channel	Index channel
10	CHC7-	Input	Encoder 7 negative C channel	Index channel
11	CHU7	Input	Channel 7 U flag	Hall effect, fault code, or sub-count
12	CHV7	Input	Channel 7 V flag	Hall effect, fault code, or sub-count
13	CHW7	Input	Channel 7 W flag	Hall effect, fault code, or sub-count
14	CHT7	Input	Channel 7 T flag	Fault code, or sub-count
15	USER7	Input	General purpose user flag	Hardware capture flag, or sub-count
16	PLIM7	Input	Positive overtravel limit	Hardware capture flag
17	MLIM7	Input	Negative overtravel limit	Hardware capture flag
18	HOME7	Input	Home switch input	Hardware capture flag
19	ACCFLT7	Input	Accessory fault flag	For loss of acc supply voltage

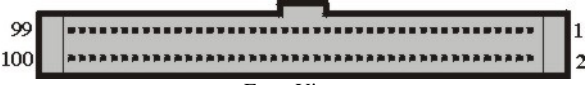
J12 JMACH4 Connector (Continued)			 Front View	
Pin#	Symbol	Function	Description	Notes
20	WD0/	Output	Watchdog output	Low is PMAC watchdog fault
21	SCLK78+	Input / Output	Encoder sample clock	Direction controlled by PMAC2 jumper
22	SCLK78-	Input / Output	Encoder sample clock	Direction controlled by PMAC2 jumper
23	ADC_CLK7+	Output	A/D converter clock	Programmable frequency
24	ADC_CLK7-	Output	A/D converter clock	Programmable frequency
25	ADC_STB7+	Output	A/D converter strobe	Programmable sequence
26	ADC_STB7-	Output	A/D converter strobe	Programmable sequence
27	ADC_DAA7+	Input	Channel A ADC serial data	MSB first
28	ADC_DAA7-	Input	Channel A ADC serial data	MSB first
29	ADC_DAB7+	Input	Channel B ADC serial data	MSB first
30	ADC_DAB7-	Input	Channel B ADC serial data	MSB first
31	AENA7+	Output	Amplifier enable	High is enable
32	AENA7-	Output	Amplifier enable	Low is enable
33	FAULT7+	Input	Amplifier fault	Programmable polarity
34	FAULT7-	Input	Amplifier fault	Programmable polarity
35	PWMATOP7+ DAC_CLK7+	Output	Phase A top Cmd. or DAC clock	Programmable function control
36	PWMATOP7- DAC_CLK7-	Output	Phase A top Cmd. or DAC clock	Programmable function control
37	PWMBOT7+ DAC7A+	Output	Phase A bottom Cmd. or DAC A serial data	Programmable function control
38	PWMBOT7- DAC7A-	Output	Phase A bottom Cmd. or DAC A serial data	Programmable function control
39	PWMBTOP7+ DAC_STB7+	Output	Phase B top Cmd. or DAC strobe	Programmable function control
40	PWMBTOP3- DAC_STB7-	Output	Phase B top Cmd. or DAC strobe	Programmable function control
41	PWMBBOT7+ DAC7B+	Output	Phase B bottom Cmd. or DAC B serial data	Programmable function control
42	PWMBBOT7- DAC7B-	Output	Phase B bottom Cmd. or DAC B serial data	Programmable function control
43	PWMC7TOP7+ DIR7+	Output	Phase B top Cmd. or PFM direction	Programmable function control
44	PWMC7TOP7- DIR7-	Output	Phase B top Cmd. or PFM direction	Programmable function control
45	PWMC7BOT7+ PULSE7+	Output	Phase B bottom Cmd. or PFM Pulse	Programmable function control
46	PWMC7BOT7- PULSE7-	Output	Phase B bottom Cmd. or PFM pulse	Programmable function control
47	GND	Common	Reference voltage	
48	GND	Common	Reference voltage	
49	+5V	Output / Input	+5V power	For external circuit or from external supply
50	+5V	Output / Input	+5V power	For external circuit or from external supply

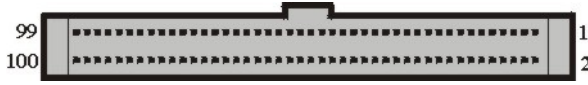
J12 JMACH4 Connector (Continued)		 <p style="text-align: center;">Front View</p>		
Pin#	Symbol	Function	Description	Notes
51	+5V	Output / Input	+5V power	For external circuit or from external Supply
52	+5V	Output / Input	+5V power	For external circuit or from external supply
53	GND	Common	Reference voltage	
54	GND	Common	Reference voltage	
55	CHA8+	Input	Encoder 8 positive A channel	Also pulse input
56	CHA8-	Input	Encoder 8 negative A channel	Also pulse input
57	CHB8+	Input	Encoder 8 positive B channel	Also direction input
58	CHB8-	Input	Encoder 8 negative B channel	Also direction input
59	CHC8+	Input	Encoder 8 positive C channel	Index channel
60	CHC8-	Input	Encoder 8 negative C channel	Index channel
61	CHU8	Input	Channel 8 U flag	Hall effect, fault code, or sub-count
62	CHV8	Input	Channel 8 V flag	Hall effect, fault code, or sub-count
63	CHW8	Input	Channel 8 W flag	Hall effect, fault code, or sub-count
64	CHT8	Input	Channel 8 T flag	Fault code, or sub-count
65	USER8	Input	General purpose user flag	Hardware capture flag, or sub-count
66	PLIM8	Input	Positive overtravel limit	Hardware capture flag
67	MLIM8	Input	Negative overtravel limit	Hardware capture flag
68	HOME8	Input	Home switch input	Hardware capture flag
69	ACCFLT8	Input	Accessory fault flag	For loss of ACC supply voltage
70	WD0/	Output	Watchdog output	Low is PMAC watchdog fault
71	SCLK78+	Input / Output	Encoder sample clock	Direction controlled by PMAC2 jumper
72	SCLK78-	Input / Output	Encoder sample clock	Direction controlled by PMAC2 jumper
73	ADC_CLK8+	Output	A/D converter clock	Programmable frequency
74	ADC_CLK8-	Output	A/D converter clock	Programmable frequency
75	ADC_STB8+	Output	A/D converter strobe	Programmable sequence
76	ADC_STB8-	Output	A/D converter strobe	Programmable sequence
77	ADC_DAA8+	Input	Channel A ADC serial data	MSB first
78	ADC_DAA8-	Input	Channel A ADC serial data	MSB first
79	ADC_DAB8+	Input	Channel B ADC serial data	MSB first
80	ADC_DAB8-	Input	Channel B ADC serial data	MSB first
81	AENA8+	Output	Amplifier enable	High is enable
82	AENA8-	Output	Amplifier enable	Low is enable
83	FAULT8+	Input	Amplifier fault	Programmable polarity
84	FAULT8-	Input	Amplifier fault	Programmable polarity
85	PWMATOP8+ DAC_CLK8+	Output	Phase A top Cmd. or DAC clock	Programmable function control
86	PWMATOP8- DAC_CLK8-	Output	Phase A top Cmd. or DAC clock	Programmable function control
87	PWMABOT8+ DAC8A+	Output	Phase A bottom Cmd. or DAC A serial data	Programmable function control
88	PWMABOT8- DAC8A-	Output	Phase A bottom Cmd. or DAC A serial data	Programmable function control
89	PWMBTOP8+ DAC_STB8+	Output	Phase B top Cmd. or DAC strobe	Programmable function control

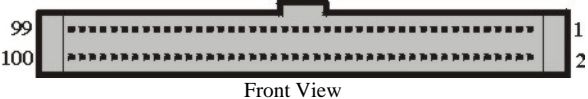
J12 JMACH4 Connector (Continued)		 <p style="text-align: center;">Front View</p>		
Pin#	Symbol	Function	Description	Notes
90	PWMBTOP8-DAC_STB8-	Output	Phase B top Cmd. or DAC strobe	Programmable function control
91	PWMBBOT8+DAC8B+	Output	Phase B bottom Cmd. or DAC B serial data	Programmable function control
92	PWMBBOT8-DAC8B-	Output	Phase B bottom Cmd. or DAC B serial data	Programmable function control
93	PWMCTOP8+DIR8+	Output	Phase B top Cmd. or PFM direction	Programmable function control
94	PWMCTOP8-DIR8-	Output	Phase B top Cmd. or PFM direction	Programmable function control
95	PWMCBOT8+PULSE8+	Output	Phase B bottom Cmd. or PFM pulse	Programmable function control
96	PWMCBOT8-PULSE8-	Output	Phase B bottom Cmd. or PFM pulse	Programmable function control
97	GND	Common	Reference voltage	
98	GND	Common	Reference voltage	
99	+5V	Output / Input	+5V power	For external circuit or from external supply
100	+5V	Output / Input	+5V power	For external circuit or from external supply

The JMACH4 connector provides the interface pins for channels 7 and 8. Usually, it is connected to a breakout board, such as one of the Acc-8x family of boards, or an application-specific interface board.

TB1 (2/4-Pin Terminal Block)

This terminal block can be used to provide the input for the power supply for the circuits on the PMAC2 board when it is not in a bus configuration. When the PMAC2 is in a bus configuration, these supplies come through the bus connector from the bus power supply automatically; in this case, this terminal block should not be used.

Pin#	Symbol	Function	Description	Notes
1	GND	Common	Reference voltage	
2	+5V	Input	Positive supply voltage	Supplies all PMAC digital circuits
3	+12V	Input	Positive supply voltage	+12v to +15v; not required on-board; used on J1 to supply analog inputs
4	-12V	Input	Negative supply voltage	-12v to -15v; required for opt-12 ADCs; used on J1 to supply analog inputs

Note: Unless Option 12 (Analog-to-Digital Converters) is included on the board, only pins 1 and 2 will be provided on this terminal block.

TB2 (3-Pin Terminal Block)

This terminal block provides the output for PMAC2's watchdog timer relay, both normally open and normally closed contacts.

Pin#	Symbol	Function	Description	Notes
1	WD_NC	Output	Watchdog relay out	Normally closed
2	COM	Input	Watchdog return	+V or 0V
3	WD_NO	Output	Watchdog relay out	Normally open

Note: The normally closed relay contact is open while PMAC2 is operating properly — it has power and the watchdog timer is not tripped. This contact is closed when the PMAC2 is not operating properly (either the PMAC has lost power or the watchdog timer has tripped). The normally open relay contact is closed while PMAC2 is operating properly, and open when PMAC2 is not operating properly.

BASE BOARD JUMPERS LAYOUT



SCHEMATICS

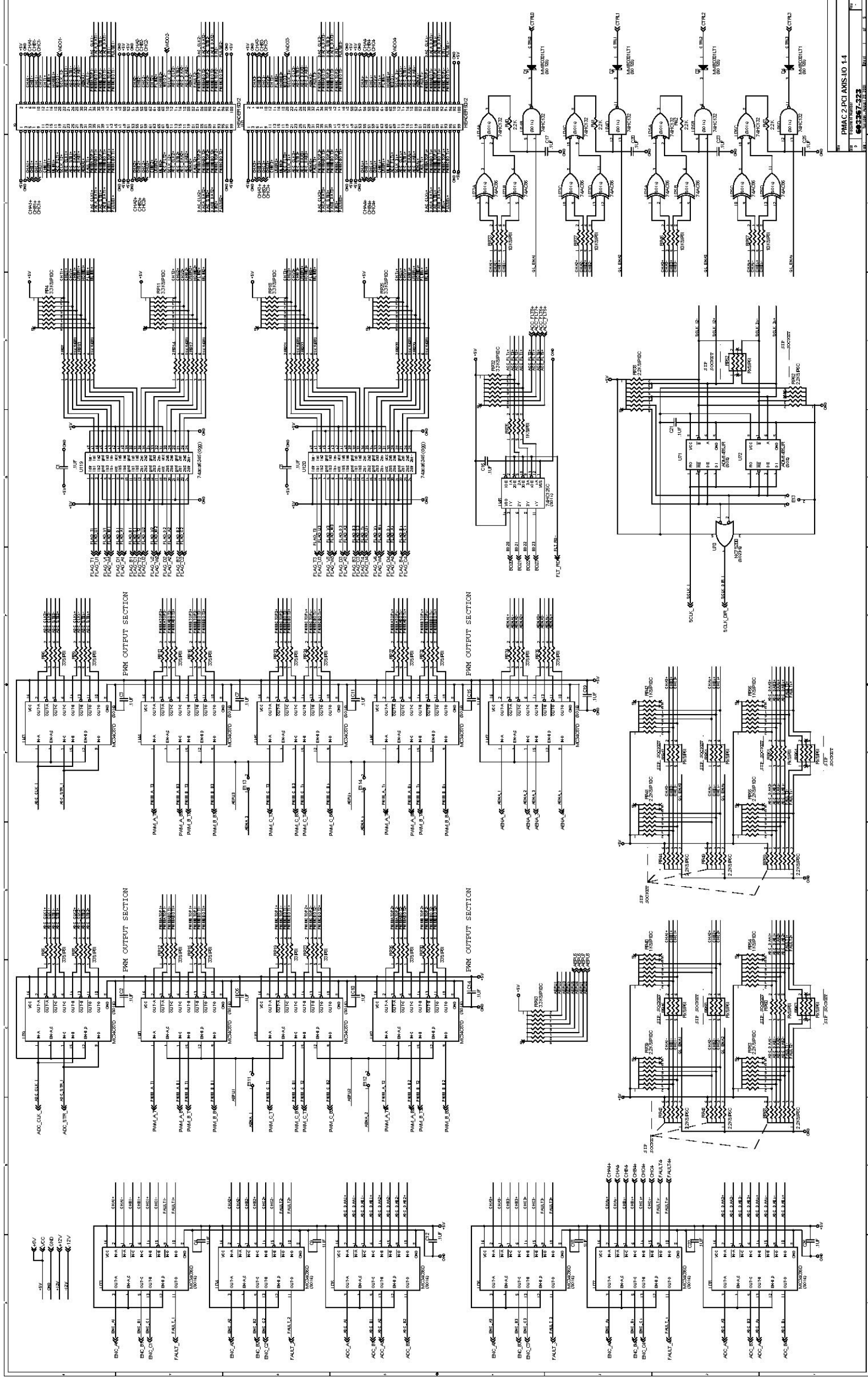

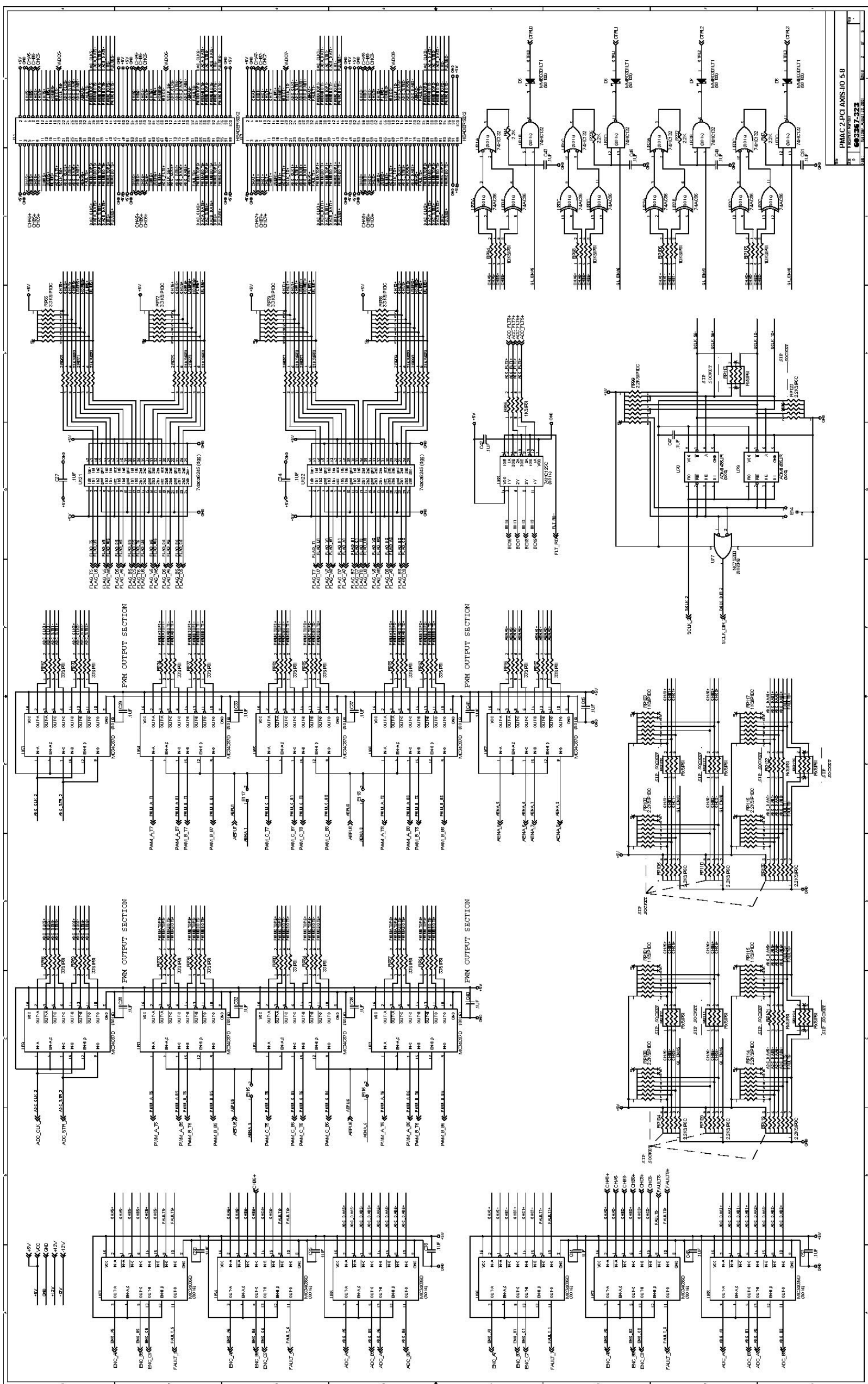

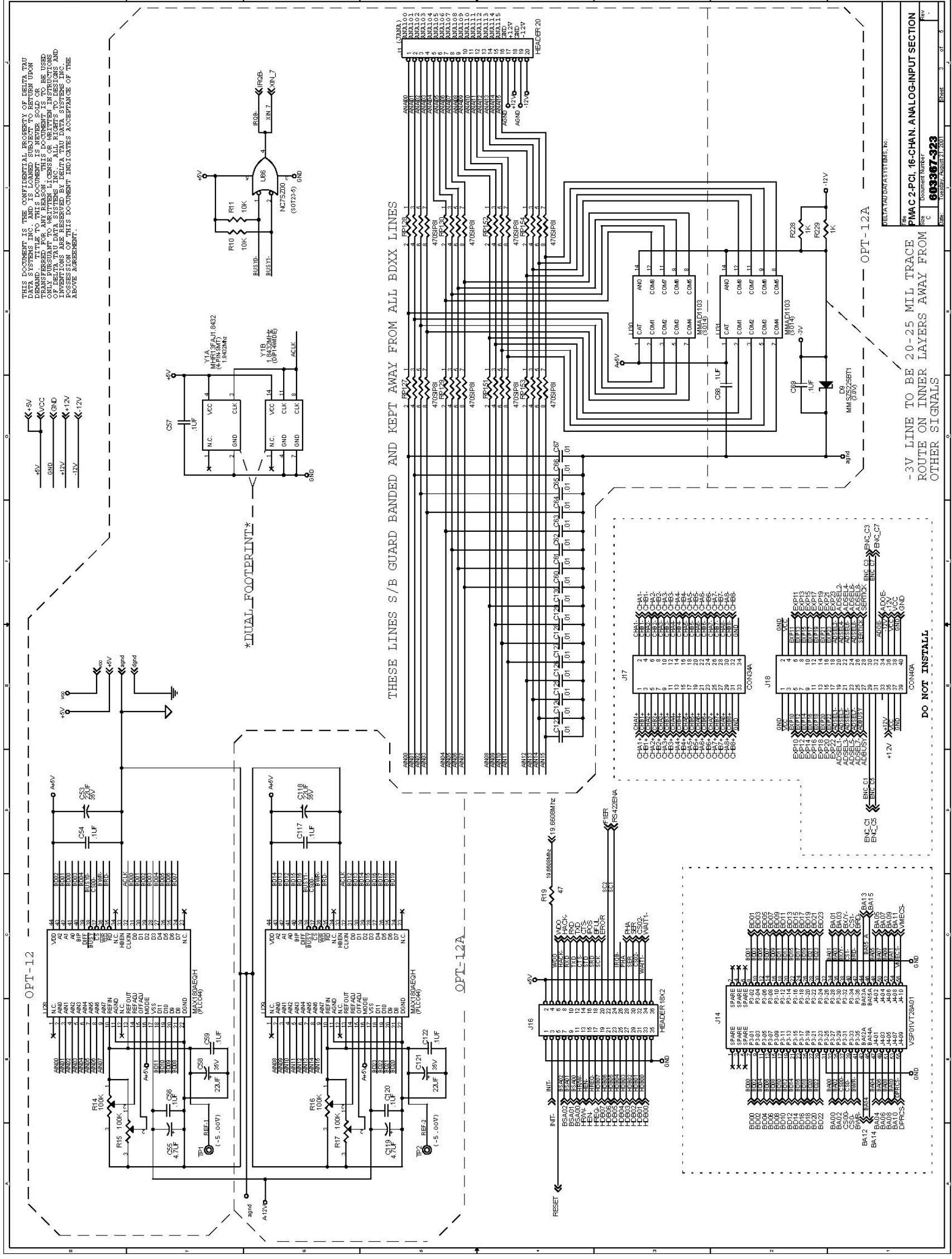

THIS DOCUMENT IS THE CONFIDENTIAL PROPERTY OF DELTA TAU DATA SYSTEMS, INC. AND IS LOANED SUBJECT TO RETURN UPON REQUEST. IT IS NOT TO BE REPRODUCED, COPIED, OR TRANSMITTED IN ANY FORM OR BY ANY MEANS, ELECTRONIC OR MECHANICAL, INCLUDING PHOTOCOPYING, RECORDING, OR BY ANY INFORMATION STORAGE AND RETRIEVAL SYSTEM. DELTA TAU DATA SYSTEMS, INC. MAKES NO WARRANTY, REPRESENTATION, OR GUARANTEE OF ANY KIND, EXPRESS OR IMPLIED, REGARDING THE ACCURACY, COMPLETENESS, OR USEFULNESS OF THE INFORMATION CONTAINED HEREIN. DELTA TAU DATA SYSTEMS, INC. ACCEPTS NO LIABILITY FOR DAMAGES OF ANY KIND, INCLUDING CONSEQUENTIAL DAMAGES, ARISING FROM THE USE OF THIS DOCUMENT.

DO NOT INSTALL

DELTA TAU DATA SYSTEMS, INC.
 PMAC2-PCI, 16-CHAN ANALOG-INPUT SECTION
 Document Number
603367-323
 REV. C
 01 02 03 04 05

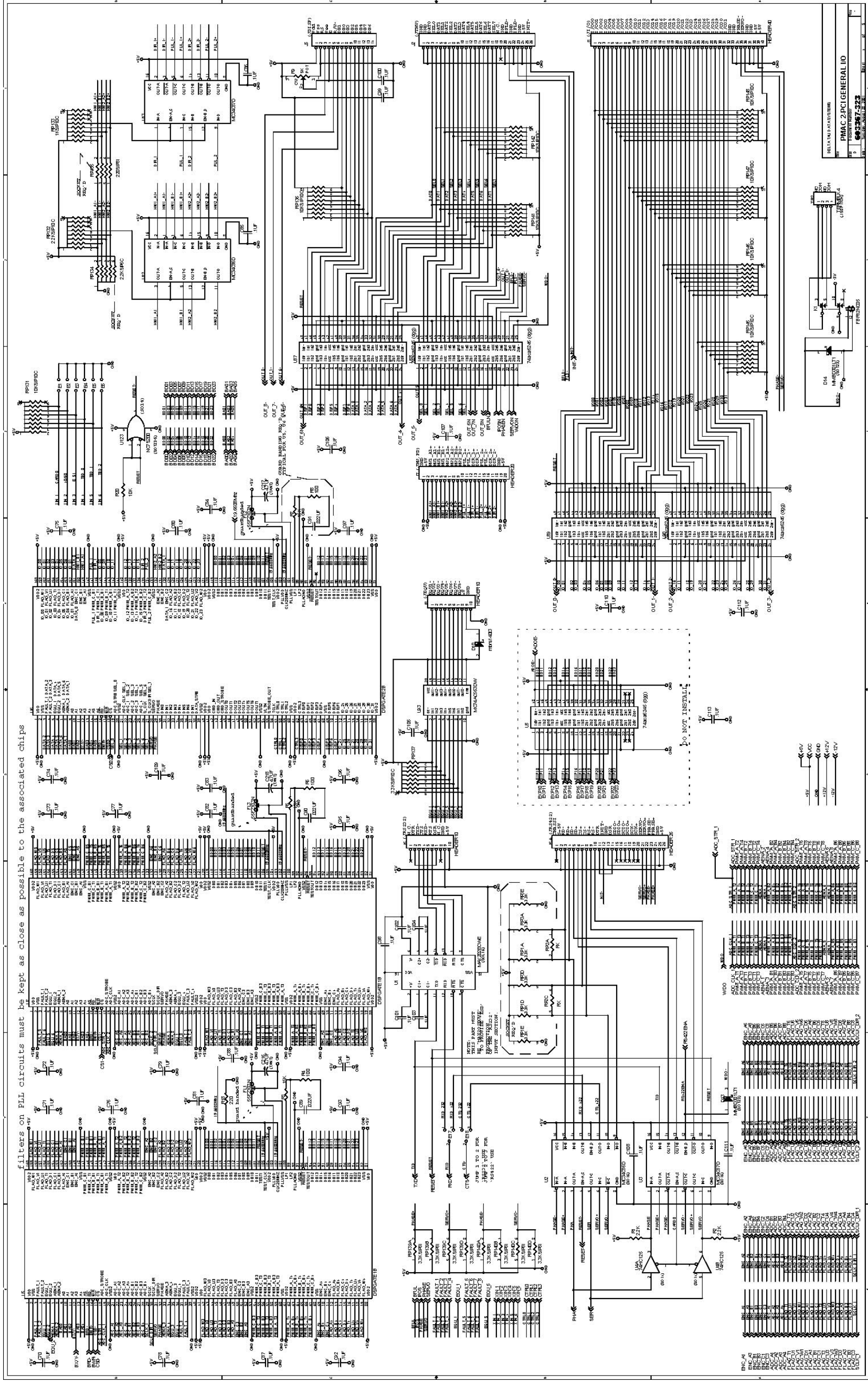

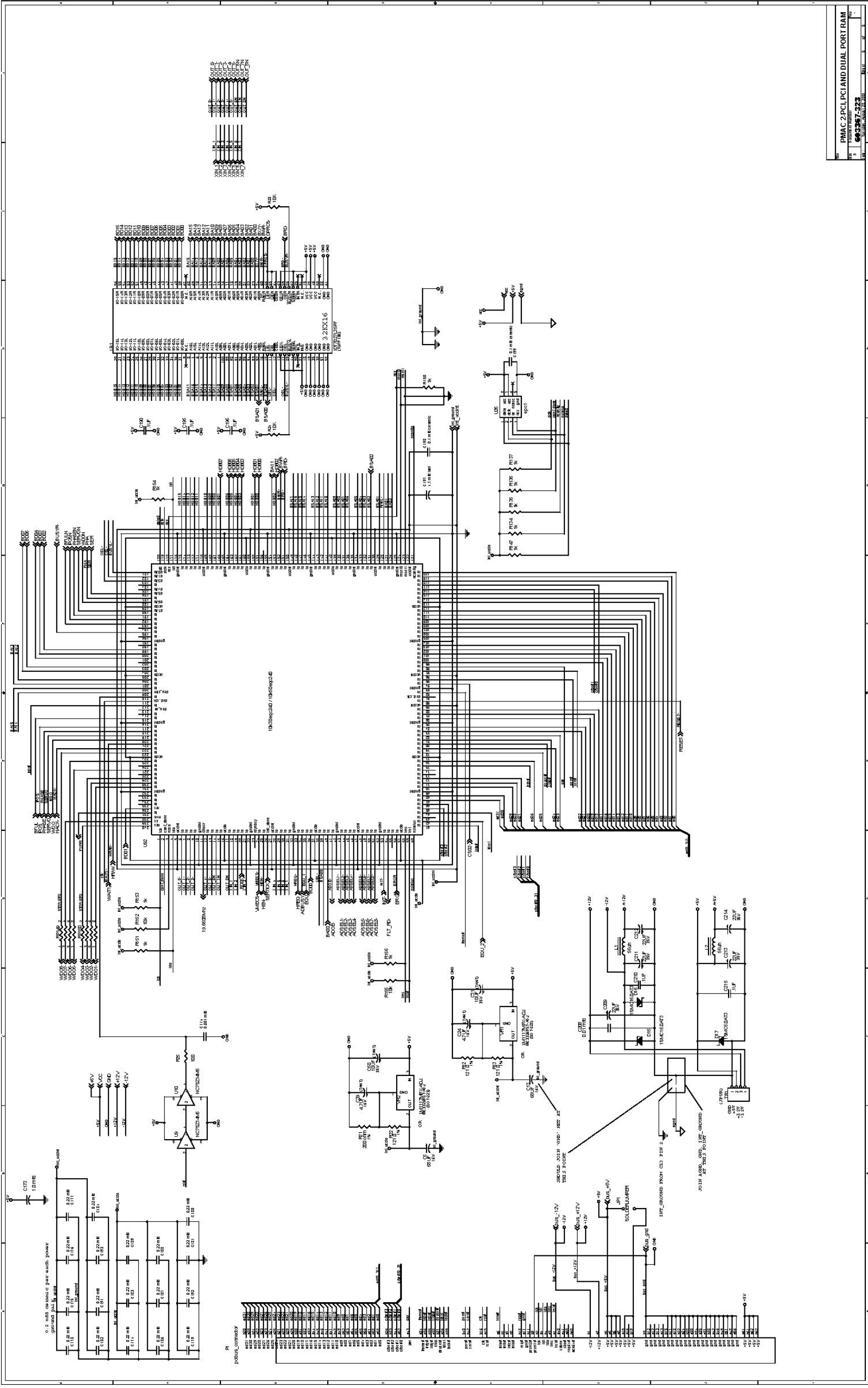

PMAC2-PCI AND DUAL PORT RAM
REV. 1.0
DATE: 06/25/97