

User Manual

Accessory 8E

Analog Servo Interface Board

3Ax-602469-xUxx

February 11, 2005



DELTA TAU
Data Systems, Inc.

NEW IDEAS IN MOTION ...

Copyright Information

© 2003 Delta Tau Data Systems, Inc. All rights reserved.

This document is furnished for the customers of Delta Tau Data Systems, Inc. Other uses are unauthorized without written permission of Delta Tau Data Systems, Inc. Information contained in this manual may be updated from time-to-time due to product improvements, etc., and may not conform in every respect to former issues.

To report errors or inconsistencies, call or email:

Delta Tau Data Systems, Inc. Technical Support

Phone: (818) 717-5656

Fax: (818) 998-7807

Email: support@deltatau.com

Website: <http://www.deltatau.com>

Operating Conditions

All Delta Tau Data Systems, Inc. motion controller products, accessories, and amplifiers contain static sensitive components that can be damaged by incorrect handling. When installing or handling Delta Tau Data Systems, Inc. products, avoid contact with highly insulated materials. Only qualified personnel should be allowed to handle this equipment.

In the case of industrial applications, we expect our products to be protected from hazardous or conductive materials and/or environments that could cause harm to the controller by damaging components or causing electrical shorts. When our products are used in an industrial environment, install them into an industrial electrical cabinet or industrial PC to protect them from excessive or corrosive moisture, abnormal ambient temperatures, and conductive materials. If Delta Tau Data Systems, Inc. products are directly exposed to hazardous or conductive materials and/or environments, we cannot guarantee their operation.

Table of Contents

INTRODUCTION	1
Overview	1
Functionality	1
<i>Analog Outputs</i>	1
<i>Amplifier Enable Outputs</i>	1
<i>Encoder Inputs</i>	1
<i>Main Input Flags</i>	1
<i>Supplemental Input Flags</i>	2
Power Supply	2
CONNECTORS.....	3
CONNECTOR PINOUTS	5
<i>JMACH (100-Pin Header)</i>	5
<i>JMACH (100-Pin Header)</i>	6
<i>JMACH (100-Pin Header)</i>	7
<i>J1 (10-Pin Header)</i>	8
<i>J2 (10-Pin Header)</i>	8
<i>J3 (14-Pin Header)</i>	9
<i>J4 (16-Pin Header)</i>	9
<i>TB1 (4-Pin Terminal Block)</i>	10
<i>TB2 (12-Pin Terminal Block) [8-Pin Terminal Block on -100 boards]</i>	10
<i>TB3 (12-Pin Terminal Block) [8-Pin Terminal Block on -100 boards]</i>	11
<i>TB4 (6-Pin Terminal Block)</i>	11
<i>TB5 (12-Pin Terminal Block)</i>	12
<i>TB6 (6-Pin Terminal Block)</i>	12
<i>TB7 (12-Pin Terminal Block)</i>	13
<i>TB8 (2-Pin Terminal Block)</i>	13
JUMPER DESCRIPTIONS	15
BOARD LAYOUT.....	17
TYPICAL WIRING	19

INTRODUCTION

Overview

The Accessory 8E for the PMAC2 family of controllers provides the pinouts for two axes with analog-input amplifiers. The amplifiers can be velocity-mode, torque-mode, or sinusoidal input mode (two analog commands); or any mix of the above.

The Acc-8E board has a single flat-cable connection to the PMAC2. All of the main signals to and from the machine can be wired through modular removable terminal blocks. Alternatively, many signals can be connected to the machine through flat cables via on-board IDC headers.

Functionality

Analog Outputs

The Acc-8E has four 18-bit D/A converters (DACs) to command the amplifiers with optical isolation from PMAC circuitry. The analog outputs have a range of -10V to +10V, and a maximum current output of 10 mA. These outputs are clamped to 0V by on-board hardware on loss of any of the on-board power-supplies (+15V, -15V, or +5V) by the amplifier-enable signal going false, or by tripping of PMAC2's watchdog timer.

Note:

Because the analog outputs are active only if the amplifier-enable signal is true, when these outputs are used for non-servo purposes, including diagnostic testing, the amplifier-enable signal for the axis must be set true.

Amplifier Enable Outputs

The amplifier-enable outputs are through dry-contact relays, user configurable with jumpers for normally open, normally closed, sinking or sourcing. The watchdog timer output is also through a dry-contact relay, with the user's choice of normally open or normally closed contacts.

Encoder Inputs

Quadrature encoder inputs can be brought into the Acc-8E either through terminal blocks or 10-pin headers. These signals are not isolated from the PMAC2. The inputs are tied directly to 5V differential line receivers on the PMAC2. The main (non-complementary) lines have 1 k Ω pull-up resistors; the complementary lines are tied to 2.5V (reversing a SIP on the PMAC2 converts this to a pull-up). The complementary lines must be left floating if single-ended inputs are used. The 5V supply for the encoder can be provided through the headers or terminal blocks.

If optical isolation of the encoder signals is desired, the Acc-8D Option 6 Isolator board may be used in conjunction with the Acc-8E board.

Main Input Flags

The main input flags (HOMEn, PLIMn, MLIMn, USERn, and AMP_FLTn) for both axes pass through AC Opto modules, which provide optical isolation with sinking or sourcing capability to 24V. For the HOMEn, PLIMn, MLIMn, and USERn flags, the return line is called FLG_n_RTn. If sinking drivers or hard contacts to 0V are used, the return line on the terminal block must be tied to the supply voltage (+12V to +24V). If sourcing drivers or hard contacts to +V are used, the return line on the terminal block must be tied to the 0V common for the flags. The AMP_FLTn input has + and - lines; the + line can be tied to the supply voltage, or the - line can be tied to 0V. In either current direction, there is a 1 k Ω 1/2W resistor in series with the opto LED.

Note:

If the User flag is brought in here, the unisolated User flag input on J3 must be left floating (see below).

Supplemental Input Flags

The supplemental flags T, U, V, and W, plus the User flag, for both axes can be brought in through header J3. These 5V CMOS inputs are directly tied to the inputs on the PMAC2 (no isolation), where they have 10 k Ω pull-up resistors.

The supplemental flags can be used for fault codes, hall-effect sensors, or sub-count interpolation.

Note:

If the User flag is brought in here, the isolated User flag input on the terminal block must be left floating (see above).

Power Supply

The Acc-8E requires a +/-12V to +/-15V power supply provided through TB1. Often, this will be provided from the bias power supply of the amplifier. This supply should be isolated from the PMAC2's 5V supply. The current requirements are under 200 mA for each voltage.

A small amount of 5V power referenced to PMAC2's common (GND) is required for on-board circuitry, and commonly for the encoders connected through the Acc-8E. Usually, this power is brought in from PMAC2 by the 100-pin connector and passed through jumper E1 on the Acc-8E. However, if the cable is very long, or the encoders require a lot of power, it is possible to remove jumper E1 and provide 5V locally through TB2. This supply common is tied automatically to PMAC2's common through the Acc-8E.

CONNECTORS

JMACH	100-pin high-density header to matching JMACHn header on PMAC2 (n=1 to 4)
J1	10-pin IDC header for connection to 1st encoder in HP-compatible pinout
J2	10-pin IDC header for connection to 2nd encoder in HP-compatible pinout
J3	14-pin IDC header for connection to supplementary input flags
J4	16-pin IDC header for flat-cable connection to 2 analog amplifiers
TB1	4-point terminal block for +/-15V power supply connection for accessory board
TB2	8-point terminal block for discrete-wired connection to 1st encoder (12-point terminal block on -101 and newer revisions to bring out pulse and direction outputs as well)
TB3	8-point terminal block for discrete-wired connection to 2nd encoder (12-point terminal block on -101 and newer revisions to bring out pulse and direction outputs as well)
TB4	6-point terminal block for connection to main flags of the 1st axis (home, limits, and user)
TB5	12-point terminal block for connection to the 1st axis amplifier (commands, enable, fault)
TB6	6-point terminal block for connection to main flags of the 2nd axis (home, limits, and user)
TB7	12-point terminal block for connection to the 2nd axis amplifier (commands, enable, fault)
TB8	2-point terminal block for optional local +5V supply for board if JMACH cable from PMAC2 is too long to provide power from PMAC2
TB9	3-point terminal block to provide normally open and normally closed dry relay contacts for PMAC2's watchdog timer output

CONNECTOR PINOUTS

JMACH (100-Pin Header)				
Pin #	Symbol	Function	Description	Notes
1	+5V	I/O	+5V Power	For external circuit or from ext. supply
2	+5V	I/O	+5V Power	For external circuit or from ext. supply
3	GND	Common	Reference Voltage	
4	GND	Common	Reference Voltage	
5	CHA1+	Output	Enc. 1 Positive A Channel	Also pulse input
6	CHA1-	Output	Enc. 1 Negative A Channel	Also pulse input
7	CHB1+	Output	Enc. 1 Positive B Channel	Also direction input
8	CHB1-	Output	Enc. 1 Negative B Channel	Also direction input
9	CHC1+	Output	Enc. 1 Positive C Channel	Index channel
10	CHC1-	Output	Enc. 1 Negative C Channel	Index channel
11	CHU1	Output	Chan. 1 U Flag	Hall Effect, Fault Code, or sub-count
12	CHV1	Output	Chan. 1 V Flag	Hall Effect, Fault Code, or sub-count
13	CHW1	Output	Chan. 1 W Flag	Hall Effect, Fault Code, or sub-count
14	CHT1	Output	Chan. 1 T Flag	Fault code, or sub-count
15	USER1	Output	Gen. Purpose User Flag	Hardware capture flag, or sub-count
16	PLIM1	Output	Pos. Overtravel Limit	Hardware capture flag
17	MLIM1	Output	Neg. Overtravel Limit	Hardware capture flag
18	HOME1	Output	Home Switch Input	Hardware capture flag
19	ACCFLT1	Output	Accessory Fault Flag	For loss of acc. supply voltage
20	WD0/	Input	Watchdog Output	Low is PMAC watchdog fault
21	SCLK12+	I/O	Encoder Sample Clock	Direction controlled by PMAC2 jumper
22	SCLK12-	I/O	Encoder Sample Clock	Direction controlled by PMAC2 jumper
23	ADC_CLK1+	Input	A/D Converter Clock	Not used on Acc-8E
24	ADC_CLK1-	Input	A/D Converter Clock	Not used on Acc-8E
25	ADC_STB1+	Input	A/D Converter Strobe	Not used on Acc-8E
26	ADC_STB1-	Input	A/D Converter Strobe	Not used on Acc-8E
27	ADC_DAA1+	Output	Chan A ADC Serial Data	No-connect on Acc-8E
28	ADC_DAA1-	Output	Chan A ADC Serial Data	No-connect on Acc-8E
29	ADC_DAB1+	Output	Chan B ADC Serial Data	No-connect on Acc-8E
30	ADC_DAB1-	Output	Chan B ADC Serial Data	No-connect on Acc-8E
31	AENA1+	Input	Amplifier Enable	High is enable
32	AENA1-	Input	Amplifier Enable	Low is enable
33	FAULT1+	Output	Amplifier Fault	Programmable polarity
34	FAULT1-	Output	Amplifier Fault	Programmable polarity
35	PWMATOP1+ DAC_CLK1+	Input	Phase A Top CMD or DAC Clock	Programmable function control
36	PWMATOP1- DAC_CLK1-	Input	Phase A Top CMD or DAC Clock	Programmable function control
37	PWMABOT1+ DAC1A+	Input	Phase A Bottom CMD or DAC A Serial Data	Programmable function control
38	PWMABOT1- DAC1A-	Input	Phase A Bottom CMD or DAC A Serial Data	Programmable function control

JMACH (100-Pin Header) (Continued)				
Pin #	Symbol	Function	Description	Notes
39	PWMBTOP1+ DAC_STB1+	Input	Phase B Top CMD or DAC Strobe	Programmable function control
40	PWMBTOP1- DAC_STB1-	Input	Phase B Top CMD or DAC Strobe	Programmable function control
41	PWMBBOT1+ DAC1B+	Input	Phase B Bottom CMD or DAC B Serial Data	Programmable function control
42	PWMBBOT1- DAC1B-	Input	Phase B Bottom CMD or DAC B Serial Data	Programmable function control
43	PWMCTOP1+ DIR1+	Input	Phase B Top CMD or PFM Direction	Programmable function control
44	PWMCTOP1- DIR1-	Input	Phase B Top CMD or PFM Direction	Programmable function control
45	PWMCBOT1+ PULSE1+	Input	Phase B Bottom CMD or PFM Pulse	Programmable function control
46	PWMCBOT1- PULSE1-	Input	Phase B Bottom CMD or PFM Pulse	Programmable function control
47	GND	Common	Reference Voltage	
48	GND	Common	Reference Voltage	
49	+5V	I/O	+5V Power	For external circuit or from ext. supply
50	+5V	I/O	+5V Power	For external circuit or from ext. supply
51	+5V	I/O	+5V Power	For external circuit or from ext. supply
52	+5V	I/O	+5V Power	For external circuit or from ext. supply
53	GND	Common	Reference Voltage	
54	GND	Common	Reference Voltage	
55	CHA2+	Output	Enc. 2 Pos. A Chan.	Also pulse input
56	CHA2-	Output	Enc. 2 Neg. A Chan.	Also pulse input
57	CHB2+	Output	Enc. 2 Pos. B Chan.	Also direction input
58	CHB2-	Output	Enc. 2 Neg. B Chan.	Also direction input
59	CHC2+	Output	Enc. 2 Pos. C Chan.	Index channel
60	CHC2-	Output	Enc. 2 Neg. C Chan.	Index channel
61	CHU2	Output	Chan 2 U Flag	Hall Effect, Fault Code, or Sub-count
62	CHV2	Output	Chan 2 V Flag	Hall Effect, Fault Code, or Sub-count
63	CHW2	Output	Chan 2 W Flag	Hall Effect, Fault Code, or Sub-count
64	CHT2	Output	Chan 2 T Flag	Fault Code, or sub-count
65	USER2	Output	Gen. Purpose User Flag	Hardware capture flag, or sub-count
66	PLIM2	Output	Positive Overtravel Limit	Hardware capture flag
67	MLIM2	Output	Neg. Overtravel Limit	Hardware capture flag
68	HOME2	Output	Home Switch Input	Hardware capture flag
69	ACCFLT2	Input	Accessory Fault Flag	For loss of acc. supply voltage
70	WD0/	Output	Watchdog Output	Low is PMAC watchdog fault
71	SCLK12+	I/O	Encoder Sample Clock	Direction controlled by PMAC2 jumper
72	SCLK12-	I/O	Encoder Sample Clock	Direction controlled by PMAC2 jumper
73	ADC_CLK2+	Input	A/D Converter Clock	Programmable frequency
74	ADC_CLK2-	Input	A/D Converter Clock	Programmable frequency
75	ADC_STB2+	Input	A/D Converter Strobe	Programmable sequence
76	ADC_STB2-	Input	A/D Converter Strobe	Programmable sequence
77	ADC_DAA2+	Output	Chan. A ADC Serial Data	MSB first

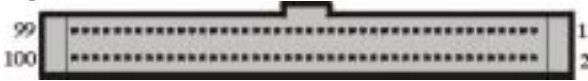
JMACH (100-Pin Header) (Continued)			Top View	
				
78	ADC_DAA2-	Output	Chan. A ADC Serial Data	MSB first
79	ADC_DAB2+	Output	Chan. B ADC Serial Data	MSB first
80	ADC_DAB2-	Output	Chan. B ADC Serial Data	MSB first
81	AENA2+	Input	Amplifier Enable	High is enable
82	AENA2-	Input	Amplifier Enable	Low is enable
83	FAULT2+	Output	Amplifier Fault	Programmable polarity
84	FAULT2-	Output	Amplifier Fault	Programmable polarity
85	PWMATOP2+ DAC_CLK2+	Input	Phase A Top CMD or DAC Clock	Programmable function control
86	PWMATOP2- DAC_CLK2-	Input	Phase A Top CMD or DAC Clock	Programmable function control
87	PWMABOT2+ DAC2A+	Input	Phase A Bottom CMD or DAC A Serial Data	Programmable function control
88	PWMABOT2- DAC2A-	Input	Phase A Bottom CMD or DAC A Serial Data	Programmable function control
89	PWMBTOP2+ DAC_STB2+	Input	Phase B Top CMD or DAC Strobe	Programmable function control
90	PWMBTOP2- DAC_STB2-	Input	Phase B Top CMD or DAC Strobe	Programmable function control
91	PWMBBOT2+ DAC2B+	Input	Phase B Bottom CMD or DAC B Serial Data	Programmable function control
92	PWMBBOT2- DAC2B-	Input	Phase B Bottom CMD or DAC B Serial Data	Programmable function control
93	PWMCTOP2+ DIR2+	Input	Phase B Top CMD or PFM Direction	Programmable function control
94	PWMCTOP2- DIR2-	Input	Phase B Top CMD or PFM Direction	Programmable function control
95	PWMCBOT2+ PULSE2+	Input	Phase B Bottom CMD. or PFM Pulse	Programmable function control
96	PWMCBOT2- PULSE2-	Input	Phase B Bottom CMD or PFM Pulse	Programmable function control
97	GND	Common	Reference Voltage	
98	GND	Common	Reference Voltage	
99	+5V	I/O	+5V Power	For external circuit or from ext. supply
100	+5V	I/O	+5V Power	For external circuit or from ext. supply
<p>This header provides the connection to the matching 100-pin header on the PMAC2. It contains all of the input and output signals between this board and the PMAC2.</p> <p>Note: On the Acc-8E, all channels are numbered 1 and 2. However, if the Acc-8E is connected to PMAC2's JMACH2, they represent PMAC2 channels 3 and 4, respectively. If the Acc-8E is connected to PMAC2's JMACH3, they represent PMAC2 channels 5 and 6, respectively. If the Acc-8E is connected to PMAC2's JMACH4, they represent PMAC2 channels 7 and 8, respectively.</p> <p>Cable Manufacturers Part Number Specification 100-Pin ribbon cable connector from AMP AMPMODU System 50 Ribbon Connector – 0.025 Centerline AMP Part Number – 1-111196-6Maximum Length = 18in. (46cm.)</p>				

J1 (10-Pin Header)			 Top View	
Pin #	Symbol	Function	Description	Notes
1	CHA1+	Input	Enc. 1 Pos. A Channel	Also pulse input
2	+5V	Output	Digital Supply Voltage	For encoder power
3	GND	Common	Reference Voltage	
4	CHA1-	Input	Enc. 1 Neg. A Channel	Also pulse input
5	CHb1-	Input	Enc. 1 Neg. B Channel	Also direction input
6	GND	Common	Reference Voltage	
7	+5V	Output	Digital Supply Voltage	For encoder power
8	CHb1+	Input	Enc. 1 Pos. B Channel	Also direction input
9	+5V	Output	Digital Supply Voltage	For encoder power
10	CHc1+	Input	Enc. 1 Pos. C Channel	Index channel

This header provides the connection to a single quadrature encoder or the signals simulated for one from an amplifier or accessory board. The signals on this connector are also available on TB2.

J2 (10-Pin Header)			 Top View	
Pin #	Symbol	Function	Description	Notes
1	CHA2+	Input	Enc. 1 Pos. A Channel	Also pulse input
2	+5V	Output	Digital Supply Voltage.	For encoder power
3	GND	Common	Reference Voltage	
4	CHA2-	Input	Enc. 1 Neg. A Channel	Also pulse input
5	CHb2-	Input	Enc. 1 Neg. B Channel	Also direction input
6	GND	Common	Reference Voltage	
7	+5V	Output	Digital Supply Voltage.	For encoder power
8	CHb2+	Input	Enc. 1 Pos. B Channel	Also direction input
9	+5V	Output	Digital Supply Voltage.	For encoder power
10	CHc2+	Input	Enc. 1 Pos. C Channel	Index channel

This header provides the connection to a single quadrature encoder or the signals simulated for one from an amplifier or accessory board. The signals on this connector are also available on TB2.

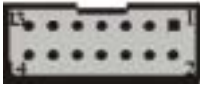
J3 (14-Pin Header)			 Top View	
Pin #	Symbol	Function	Description	Notes
1	CHT1	Input	Supplementary Flag T	Fault Code, or sub-count
2	NC		No connect	
3	CHU1	Input	Supplementary Flag U	Hall Effect, Fault Code, or sub-count
4	CHV1	Input	Supplementary Flag V	Hall Effect, Fault Code, or sub-count
5	CHW1	Input	Supplementary Flag W	Hall Effect, Fault Code, or sub-count
6	USER1	Input	General Purpose User Flag	Hardware capture flag, or sub-count
7	CHT2	Input	Supplementary Flag T	Fault Code, or sub-count
8	NC		No connect	
9	CHU2	Input	Supplementary Flag U	Hall Effect, Fault Code, or sub-count
10	CHV2	Input	Supplementary Flag V	Hall Effect, Fault Code, or sub-count
11	CHW2	Input	Supplementary Flag W	Hall Effect, Fault Code, or sub-count
12	USER2	Input	General Purpose User Flag	Hardware capture flag, or sub-count
13	GND	Common	Reference Voltage	
14	+5V	Output	Supply Voltage	

This header provides the connection to supplemental input flags that can be used for sub-count interpolation, hall-effect commutation, or amplifier fault codes. The USER flags can also be input on TB4 or TB6.

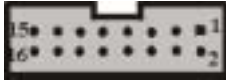
J4 (16-Pin Header)			 Top View	
Pin #	Symbol	Function	Description	Notes
1	DAC1A+	Output	Phase A Analog Out	+/-10V, ref to AGND
2	DAC1A-	Output	Phase A Analog Out	-/+10V; ref to AGND
3	DAC1B+	Output	Phase B Analog Out	+/-10V, ref to AGND
4	DAC1B-	Output	Phase B Analog Out	-/+10V; ref to AGND
5	DAC2A+	Output	Phase A Analog Out	+/-10V, ref to AGND
6	DAC2A-	Output	Phase A Analog Out	-/+10V; ref to AGND
7	DAC2B+	Output	Phase B Analog Out	+/-10V, ref to AGND
8	DAC2B-	Output	Phase B Analog Out	-/+10V; ref to AGND
9	AMP_ENA1+	Output	Amplifier Enable	
10	AMP_ENA1+	Output	Amplifier Enable	
11	AMP_ENA2+	Output	Amplifier Enable	
12	AMP_ENA2+	Output	Amplifier Enable	
13	AGND	Common	Analog Reference Voltage	
14	A+15V	I/O	Analog Positive Supply Voltage	
15	AGND	Common	Analog Reference Voltage	
16	A-15V	I/O	Analog Negative Supply Voltage	

This header provides amplifier command signals for two axes. These signals can also be output on TB5 and TB7.

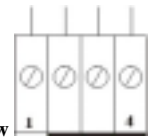
TB1 (4-Pin Terminal Block)			 <p style="text-align: center;">Top View</p>	
Pin #	Symbol	Function	Description	Notes
1	AGND	Common	Analog Reference Voltage	
2	A+15V	I/O	Analog Positive Supply Voltage	
3	AGND	Common	Analog Reference Voltage	
4	A-15V	I/O	Analog Negative Supply Voltage	
This terminal block provides the input for the power supply for the analog circuits on the board.				

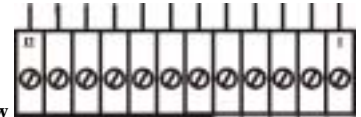
TB2 (12-Pin Terminal Block) [8-Pin Terminal Block on -100 boards]			 <p style="text-align: center;">Top View</p>	
Pin #	Symbol	Function	Description	Notes
1	CHA1+	Input	Enc. 1 Pos. A Channel	Also pulse input
2	CHA1-	Input	Enc. 1 Neg. A Channel	Also pulse input
3	CHB1+	Input	Enc. 1 Pos. B Channel	Also direction input
4	CHB1-	Input	Enc. 1 Neg. B Channel	Also direction input
5	CHC1+	Input	Enc. 1 Pos. C Channel	Index channel
6	CHC1-	Input	Enc. 1 Neg. C Channel	Index channel
7	+5V	Output	Digital Supply	
8	GND	Common	Digital Reference	
9	PULSE1+	Output	Pulse Frequency Out	Not on -100 boards
10	PULSE1-	Output	Pulse Frequency Out	Not on -100 boards
11	DIR1+	Output	Pulse Direction Out	Not on -100 boards
12	DIR1-	Output	Pulse Direction Out	Not on -100 boards
This terminal block provides the interface to a single quadrature encoder or the signals of a simulated encoder. On -101 and newer versions, it also provides pulse and direction outputs for stepper motor drives and magnetostrictive linear displacement transducers (MLDTs) such as the Temposonics brand. The encoder signals can also be brought in on J1.				

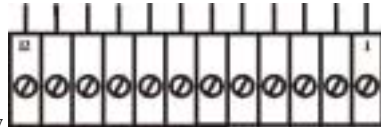
TB3 (12-Pin Terminal Block) [8-Pin Terminal Block on -100 boards]				 Top View
Pin #	Symbol	Function	Description	Notes
1	CHA2+	Input	Enc. 2 Pos. A Channel	Also pulse input
2	CHA2-	Input	Enc. 2 Neg. A Channel	Also pulse input
3	CHB2+	Input	Enc. 2 Pos. B Channel	Also direction input
4	CHB2-	Input	Enc. 2 Neg. B Channel	Also direction input
5	CHC2+	Input	Enc. 2 Pos. C Channel	Index Channel
6	CHC2-	Input	Enc. 2 neg. C Channel	Index Channel
7	+5V	Output	Digital Supply	
8	GND	Common	Digital Reference	
9	PULSE2+	Output	Pulse Frequency Out	Not on -100 boards
10	PULSE2-	Output	Pulse Frequency Out	Not on -100 boards
11	DIR2+	Output	Pulse Direction Out	Not on -100 boards
12	DIR2-	Output	Pulse Direction Out	Not on -100 boards

This terminal block provides the interface to a single quadrature encoder or the signals of a simulated encoder. On -101 and newer versions, it also provides pulse and direction outputs for stepper motor drives and magnetostrictive linear displacement transducers (MLDTs) such as the Temposonics brand. The encoder signals can also be brought in on J2.

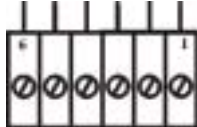
TB4 (6-Pin Terminal Block)				 Top View
Pin #	Symbol	Function	Description	Notes
1	User1	Input	General Capture Flag	Sinking or sourcing
2	Plim1	Input	Positive Limit Flag	Sinking or sourcing
3	Mlim1	Input	Negative Limit Flag	Sinking or sourcing
4	Home1	Input	Home Flag	Sinking or sourcing
5	Flg_1_ret	Common	Return for All Flags	+V (12 to 24V) or 0V
6	Flg_1_ret	Common	Return for All Flags	+V (12 to 24V) or 0V

This terminal block provides the connection for the standard machine input flags for an axis. The USER flag can also be brought in on J3.

Note: If sinking-output drivers are to be used for the flags on this terminal block, the Flag Return lines should be connected to the positive supply voltage so that the outputs can sink the current from the board. If sourcing-output drivers are to be used, the Flag Return lines should be connected to the zero volt reference for the circuit so that the outputs can source current into the board.

TB5 (12-Pin Terminal Block)			 Acc-8E	
Pin #	Symbol	Function	Description	Notes
1	DAC1A+	Output	Phase A Analog Out	
2	DAC1A-	Output	Phase A Analog Out	
3	AGND	Common	Analog Reference Voltage	
4	DAC1B+	Output	Phase B Analog Out	
5	DAC1B-	Output	Phase B Analog Out	
6	AGND	Common	Analog Reference Voltage	
7	AMP_ENA1+	Output	Amplifier Enable	Relay output; jumper-set polarity (E2-E4)
8	AMP_ENA1-	Output	Amplifier Enable	Relay output; jumper-set polarity (E2-E4)
9	AMP_FLT1+	Input	Amplifier Fault	Programmable Polarity
10	AMP_FLT1-	Input	Amplifier Fault	Programmable Polarity
11	AGND	Common	Analog Reference Voltage	
12	AGND	Common	Analog Reference Voltage	

This terminal block provides the connection for an analog-input amplifier (one or two analog commands) including the enable/fault handshaking lines). The analog commands and enable signals can also be brought out on J4.

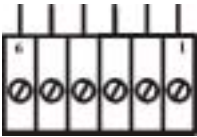
TB6 (6-Pin Terminal Block)			 Top View	
Pin #	Symbol	Function	Description	Notes
1	USER2	Input	General Capture Flag	Sinking or sourcing
2	PLIM2	Input	Positive Limit Flag	Sinking or sourcing
3	MLIM2	Input	Negative Limit Flag	Sinking or sourcing
4	HOME2	Input	Home Flag	Sinking or sourcing
5	FLG_2_RET	Common	Return for all Flags	+V (12 to 24V) or 0V
6	FLG_2_RET	Common	Return for all Flags	+V (12 to 24V) or 0V





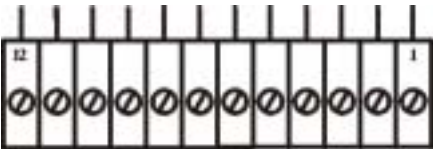

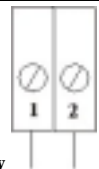
This terminal block provides the connection for the standard machine input flags for an axis. The USER flag can also be brought in on J3.

Note: If sinking-output drivers are to be used for the flags on this terminal block, the Flag Return lines should be connected to the positive supply voltage so that the outputs can sink the current from the board. If sourcing-output drivers are to be used, the Flag Return lines should be connected to the zero volt reference for the circuit so that the outputs can source current into the board.

TB7 (12-Pin Terminal Block)				 <p style="text-align: center;">Top View</p>	
Pin #	Symbol	Function	Description	Notes	
1	DAC2A+	Output	Phase A Analog Out		
2	DAC2A-	Output	Phase A Analog Out		
3	AGND	Common	Analog Reference Voltage		
4	DAC2B+	Output	Phase B Analog Out		
5	DAC2B-	Output	Phase B Analog Out		
6	AGND	Output	Analog Reference Voltage		
7	AMP_ENA2+	Output	Amplifier Enable	Relay output; jumper-set polarity (E5-E7)	
8	AMP_ENA2-	Output	Amplifier Enable	Relay output; jumper-set polarity (E5-E7)	
9	AMP_FLT2+	Input	Amplifier Fault	Programmable polarity	
10	AMP_FLT2-	Input	Amplifier Fault	Programmable polarity	
11	AGND	Output	Analog Reference Voltage		
12	AGND	Output	Analog Reference Voltage		
<p>This terminal block provides the connection for an analog-input amplifier (one or two analog commands) including the enable/fault handshaking lines. The analog commands and enable signals can also be brought out on J4.</p>					

TB8 (2-Pin Terminal Block)				 <p style="text-align: center;">Top View</p>	
Pin #	Symbol	Function	Description	Notes	
1	GND	Common	Digital Reference Voltage		
2	+5V	Input	Digital Supply Voltage		
<p>This terminal block permits +5V power to be brought in at the terminal block if the cable connection to PMAC2 is too long to provide adequate power. If power is brought in here, jumper E1 on the Acc-8E should be removed to disconnect PMAC2's +5V power.</p>					

JUMPER DESCRIPTIONS

Jumper	Configuration	Description	Default
E1		Jump pin 1 to 2 to power Acc-8E digital 5V circuitry from PMAC2 through flat cable on JMACH port. Remove jumper to separate Acc-8E digital 5V power from PMAC2 5V power. In this case, 5V power must be supplied to Acc-8E through TB8.	Jumpered
E2		Jump pin 1 to 2 for normally closed relay contact between AMP_ENA1+ and AMP_ENA1- (open when enabled) E4 must be OFF in this configuration. Remove jumper for normally open relay contact between AMP_ENA1+ and AMP_ENA1- (closed when enabled) E4 must be ON in this configuration.	Not Jumpered
E3		Jump pin 1 to 2 to tie AMP_ENA1- to AGND for single-ended amplifier-enable output – AMP_ENA1+ to AGND return. This can be used in either normally open or normally closed configuration. Remove jumper to separate AMP_ENA1- from AGND for double-ended amplifier-enable output -- AMP_ENA1+ to AMP_ENA1- return. This can be used in either normally open or normally closed configuration.	Jumpered
E4		Jump pin 1 to 2 for normally open relay contact between AMP_ENA1+ and AMP_ENA1- (closed when enabled) E2 must be OFF in this configuration. Remove jumper for normally closed relay contact between AMP_ENA1+ and AMP_ENA1- (open when enabled) E2 must be ON in this configuration.	Jumpered
E5		Jump pin 1 to 2 for normally closed relay contact between AMP_ENA2+ and AMP_ENA2- (open when enabled) E7 must be OFF in this configuration. Remove jumper for normally open relay contact between AMP_ENA2+ and AMP_ENA2- (closed when enabled) E7 must be ON in this configuration.	Not Jumpered
E6		Jump pin 1 to 2 to tie AMP_ENA2- to AGND for single-ended amplifier-enable output – AMP_ENA2+ to AGND return. This can be used in either normally open or normally closed configuration. Remove jumper to separate AMP_ENA2- from AGND for double-ended amplifier-enable output -- AMP_ENA2+ to AMP_ENA2- return. This can be used in either normally open or normally closed configuration.	Jumpered
E7		Jump pin 1 to 2 for normally open relay contact between AMP_ENA2+ and AMP_ENA2- (closed when enabled) E5 must be OFF in this configuration. Remove jumper for normally closed relay contact between AMP_ENA2+ and AMP_ENA2- (open when enabled) E5 must be ON in this configuration.	Jumpered
Note: Default for these jumpers is E2=OFF, E4=ON, E5=OFF, E7=ON.			

BOARD LAYOUT

